

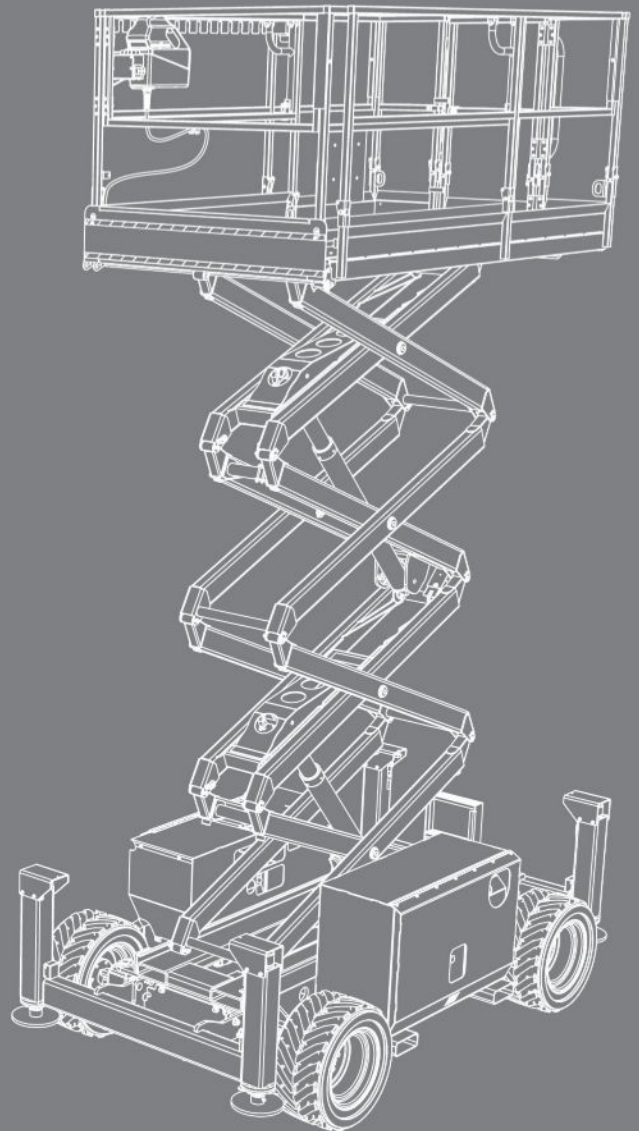

# OPERATION MANUAL

**SJ6826 RT, SJ6832 RT**

ROUGH TERRAIN SCISSORS



**221587ACA**

March 2023  
ANSI/CSA

**This manual is for MEWPs with serial numbers:**

**SJ6826 RT, SJ6832 RT: A200 000 001 & above**

**Please refer to the website ([www.skyjack.com](http://www.skyjack.com)) for contact information, other Serial Numbers, the most recent Technical Manuals, and USB software.**

The original instructions are in English.

# THIS SAFETY ALERT SYMBOL MEANS ATTENTION!



## BE ALERT! YOUR SAFETY IS INVOLVED.

The Safety Alert symbol identifies important safety messages on MEWPs, safety signs in manuals or elsewhere. When you see this symbol, be alert to the possibility of personal injury or death. Follow the instructions in the safety message.

### **DANGER**

**DANGER** indicates an imminently hazardous situation which, if not avoided, will result in death or serious injury.

### **WARNING**

**WARNING** indicates a potentially hazardous situation which, if not avoided, could result in death or serious injury.

### **CAUTION**

**CAUTION** indicates a potentially hazardous situation which, if not avoided, may result in minor or moderate injury. It may also be used to alert against unsafe practices.

### **IMPORTANT**

**IMPORTANT** indicates a procedure essential for safe operation and which, if not followed, may result in a malfunction or damage to the MEWP.

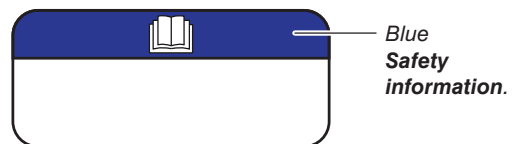
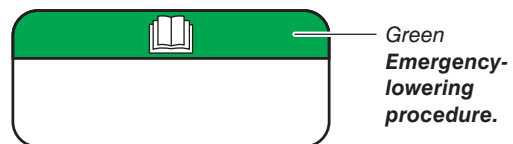
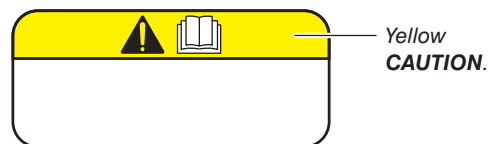
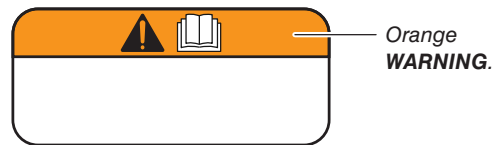
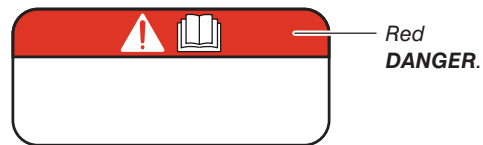



---

# Table of Contents

<b>Section 1 – About this Mobile Elevating Work Platform (MEWP)</b> .....	<b>9</b>
<b>1.1 Read and heed.</b> .....	<b>9</b>
1.1-1 <i>Mobile Elevating Work Platform (MEWP) definition</i> .....	9
1.1-2 <i>Purpose of equipment</i> .....	9
1.1-3 <i>Use of equipment</i> .....	9
1.1-4 <i>Operation manual</i> .....	9
1.1-5 <i>Operator</i> .....	9
1.1-6 <i>Service policy and warranty</i> .....	9
1.1-7 <i>Ownership of MEWP</i> .....	9
1.1-8 <i>Optional equipment</i> .....	9
1.1-9 <i>Scope of this manual</i> .....	10
<b>1.2 Primary assemblies</b> .....	<b>11</b>
<b>1.3 Serial number nameplate</b> .....	<b>12</b>
<b>1.4 Maintenance responsibility</b> .....	<b>13</b>
1.4-1 <i>Operator</i> .....	13
1.4-2 <i>Maintenance and inspection schedule</i> .....	13
1.4-3 <i>Owner</i> .....	13
<b>Section 2 – General Safety Precautions</b> .....	<b>15</b>
<b>2.1 Electrocuting hazards</b> .....	<b>15</b>
2.1-1 <i>Minimum distance from electrical conductors</i> .....	15
<b>2.2 Safety instructions</b> .....	<b>16</b>
<b>2.3 Fall-protection</b> .....	<b>19</b>
<b>2.4 Worksite inspection</b> .....	<b>19</b>
<b>Section 3 – Familiarization</b> .....	<b>21</b>
<b>3.1 Overview of the MEWP</b> .....	<b>22</b>
<b>3.2 Manual storage box</b> .....	<b>23</b>
<b>3.3 Control functions</b> .....	<b>23</b>
3.3-1 <i>Main power disconnect switch</i> .....	23
3.3-2 <i>Base control console</i> .....	24
3.3-3 <i>Platform control console</i> .....	25
<b>3.4 Features and devices</b> .....	<b>26</b>
3.4-1 <i>Lowered travel position and elevated travel position</i> .....	26
3.4-2 <i>Drive speed</i> .....	26
3.4-3 <i>Tilt switch</i> .....	26
3.4-4 <i>Brake release system</i> .....	26
3.4-5 <i>Freewheeling valve</i> .....	27

3.4-6	<i>Emergency-lowering system</i>	27
3.4-7	<i>Fall-protection anchorage</i>	28
3.4-8	<i>Platform load-sensing system</i>	28
3.4-9	<i>Maintenance support</i>	29
3.4-10	<i>Propane cylinder</i>	29
3.4-11	<i>Outriggers (optional equipment)</i>	29
<b>3.5</b>	<b>General components</b>	<b>29</b>
3.5-1	<i>AC power socket on the platform</i>	29
3.5-2	<i>Folding guardrail system</i>	29
3.5-3	<i>Extension platform</i>	30
3.5-4	<i>Motion alarm</i>	30
<b>3.6</b>	<b>Optional equipment</b>	<b>30</b>
3.6-1	<i>Secondary Guarding Lift Enable (SGLE) push-button</i>	30
3.6-2	<i>Elevate™ telematics - access control unit</i>	31
3.6-3	<i>Outrigger/generator control console</i>	32
3.6-4	<i>Hydraulic generator</i>	33
<b>Section 4 – Inspections Before Operation</b>		<b>35</b>
<b>4.1</b>	<b>Operator's Responsibility</b>	<b>35</b>
<b>4.2</b>	<b>Visual and daily maintenance inspections</b>	<b>36</b>
4.2-1	<i>Labels</i>	36
4.2-2	<i>Electrical</i>	36
4.2-3	<i>Hydraulic</i>	36
4.2-4	<i>Base</i>	37
4.2-5	<i>Wheels/Tires</i>	37
4.2-6	<i>Engine compartment</i>	38
4.2-7	<i>Hydraulic compartment</i>	40
4.2-8	<i>Platform assembly</i>	41
4.2-9	<i>Lift mechanism</i>	42
<b>4.3</b>	<b>Function Tests</b>	<b>43</b>
4.3-1	<i>Do a test of the main power disconnect switch</i>	43
4.3-2	<i>Do a test of the emergency-stop button on the base</i>	43
4.3-3	<i>Do a test of the load-sensing module self-check</i>	43
4.3-4	<i>Do a test of the idle/platform/base key switch</i>	44
4.3-5	<i>Do a test of the emergency-lowering function</i>	44
4.3-6	<i>Do a test of the positive air shutoff (optional equipment)</i>	45
4.3-7	<i>Do a test of the platform emergency-stop</i>	46
4.3-8	<i>Do a test of the function-enable switch</i>	46
4.3-9	<i>Do a test of the steer function</i>	46
4.3-10	<i>Do a test of the drive function</i>	47
4.3-11	<i>Do a test of the anti-tiedown function</i>	47
4.3-12	<i>Do a test of the brakes</i>	47
4.3-13	<i>Do a test of the platform raise and lower functions</i>	48
4.3-14	<i>Do a test of the horn</i>	48

4.3-15	<i>Do a test of the elevated travel speed</i>	48
4.3-16	<i>Do a test of the SGLE switch (optional equipment)</i>	49
4.3-17	<i>Do a test of the outrigger interlocks (optional equipment)</i>	50
4.3-18	<i>Do a test of the auto-level (optional equipment)</i>	51
4.3-19	<i>Do a test of the generator (optional equipment)</i>	52
<b>4.4</b>	<b>Operator's Checklist</b>	<b>53</b>
<b>Section 5 – Operation</b>		<b>55</b>
<b>5.1</b>	<b>Energize the base control console</b>	<b>55</b>
<b>5.2</b>	<b>Raise or lower the platform with the base control console</b>	<b>56</b>
<b>5.3</b>	<b>Energize the platform control console</b>	<b>56</b>
<b>5.4</b>	<b>Raise or lower the platform with the platform control console</b>	<b>56</b>
<b>5.5</b>	<b>Raise and lower with the SGLE platform control console (optional equipment)</b>	<b>57</b>
<b>5.6</b>	<b>Drive forward or rearward</b>	<b>57</b>
<b>5.7</b>	<b>Steer</b>	<b>57</b>
<b>5.8</b>	<b>Select the level-drive or inclined-drive mode</b>	<b>58</b>
<b>5.9</b>	<b>Extend/retract the extension platform</b>	<b>58</b>
<b>5.10</b>	<b>Use the auto-level (optional equipment)</b>	<b>59</b>
<b>5.11</b>	<b>Start and stop the generator (optional equipment)</b>	<b>59</b>
<b>5.12</b>	<b>MEWP shutdown</b>	<b>60</b>
<b>Section 6 – Additional Procedures</b>		<b>61</b>
<b>6.1</b>	<b>Use the emergency-lowering function</b>	<b>61</b>
<b>6.2</b>	<b>Release the brakes manually</b>	<b>62</b>
<b>6.3</b>	<b>Winch and tow the MEWP</b>	<b>62</b>
<b>6.4</b>	<b>Move the MEWP for transport</b>	<b>63</b>
6.4-1	<i>Lift the MEWP with a forklift</i>	63
6.4-2	<i>Hoist the MEWP</i>	64
6.4-3	<i>Drive and tie-down the MEWP</i>	65
<b>6.5</b>	<b>Use the platform control console from the ground</b>	<b>66</b>
6.5-1	<i>Disconnect and remove the platform control console</i>	66
6.5-2	<i>Operate the MEWP from the ground</i>	66
<b>6.6</b>	<b>Fold the guardrails</b>	<b>68</b>
6.6-1	<i>Fold the guardrail system down</i>	68
6.6-2	<i>Unfold the guardrail system up</i>	70
<b>6.7</b>	<b>Move the MEWP through a doorway</b>	<b>71</b>
<b>6.8</b>	<b>Use the maintenance support</b>	<b>73</b>
6.8-1	<i>Deploy the maintenance support</i>	73
6.8-2	<i>Store the maintenance support</i>	73
<b>6.9</b>	<b>Refuel</b>	<b>74</b>
6.9-1	<i>Refuel the MEWP with gasoline or diesel</i>	74
6.9-2	<i>Replace the propane cylinder (dual fuel)</i>	74
6.9-3	<i>Remove the propane cylinder</i>	75
6.9-4	<i>Install the propane cylinder</i>	75

---

<b>Section 7 – Technical Specifications</b> .....	<b>77</b>
7.1 Standard and optional equipment .....	77
7.2 Owner’s annual inspection record .....	78
7.3 Specifications .....	79
7.4 Maximum platform capacities (evenly distributed) .....	80
7.5 Environment .....	80
7.6 Floor loading pressure .....	81
<b>Section 8 – Labels</b> .....	<b>83</b>
8.1 Engine compartment .....	84
8.2 Right side .....	86
8.3 Front side .....	89
8.4 Left side .....	91
8.5 Hydraulic/fuel compartment .....	95
8.6 Rear side .....	96
8.7 Propane tank .....	98
8.8 Platform view .....	99
8.9 Platform control console .....	101
8.10 Lift cylinders .....	102
8.11 Outriggers (optional equipment) .....	103
8.12 Outrigger and generator control console (optional equipment) .....	104
8.13 Air supply options (optional equipment) .....	105
<b>Section 9 – Unique Skyjack Features</b> .....	<b>107</b>



---

# Section 1 – About this Mobile Elevating Work Platform (MEWP)

## 1.1 Read and heed

Skyjack is continuously improving and expanding product features on its equipment; therefore, specifications and dimensions are subject to change without notice.

### 1.1-1 Mobile Elevating Work Platform (MEWP) definition

A MEWP is a mobile machine intended for moving persons, tools, and material to working positions. It consists of a work platform with controls, an extending structure, and a chassis.

### 1.1-2 Purpose of equipment

The Skyjack Rough Terrain Scissor lifts are designed to move personnel, tools, and materials to working positions.

### 1.1-3 Use of equipment

The MEWP is a highly maneuverable, mobile work station. Only elevate the platform, or drive while elevated on a firm, level surface.

### 1.1-4 Operation manual

The operation manual is an essential part of the MEWP. It is important to always keep a copy of this manual in the weather-resistant manual storage box of the MEWP. The manual must be in good condition.

### 1.1-5 Operator

Before the operator operates the MEWP, they must read and completely understand this information:

1. The full contents of the operation manual, including the operating procedures, the MEWP limitations, the responsibilities of the operator for the operation, applicable maintenance, warnings and safety instructions.
2. The safety panel label on the platform, the labels on the MEWP and the attachments.

Compare the labels on the MEWP with the labels in this manual. Immediately replace any labels that are damaged or missing.

Only trained and authorized personnel are permitted to operate a MEWP.

The operator must be familiar with the employer's work rules and related government regulations.

### 1.1-6 Service policy and warranty

Skyjack warrants each new product to be free of defective parts and workmanship for the first 2 years. Your local Skyjack dealer will replace or repair any defective part, with no charge for parts or labour. In addition, all products have a 5-year structural warranty. Contact the Skyjack service department for warranty statement extensions or exclusions.

### 1.1-7 Ownership of MEWP

Notify Skyjack of MEWP ownership. If you sell or transfer the ownership of a MEWP, promptly notify Skyjack of the new owner's contact information.

Skyjack needs this information to inform the owner of any updates or additional activities that are necessary to keep the machine in proper working condition.

### 1.1-8 Optional equipment

This MEWP accepts a variety of optional equipment. Refer to [section 7.1](#) for a list of the optional accessories. [Section 5](#) contains operating instructions for these options.

For components or systems that are not standard, speak to the Skyjack Service Department. Give the model and serial number for each applicable MEWP.

### 1.1-9 Scope of this manual

1. This manual applies to the ANSI/CSA versions of the SJ Rough Terrain Scissor Lift series. For a list of applicable models, refer to [section 7.1](#).
  - Equipment identified with ANSI meets the ANSI SAIA-A92.20-2018 standard.
  - Equipment identified with CSA meets the CSA B354.6:2017 standard.

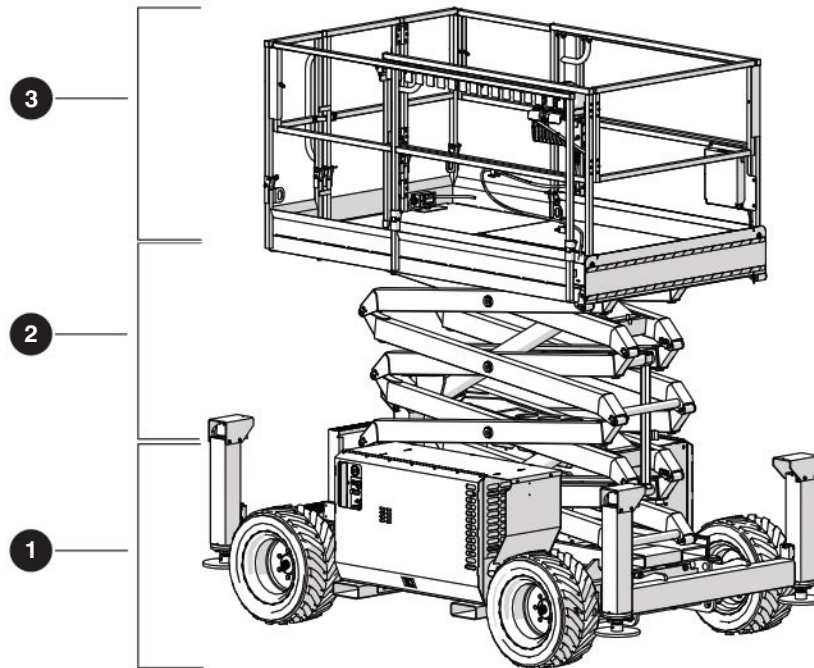

## 1.2 Primary assemblies

The MEWP has these primary assemblies:

1. Base
2. Lift mechanism
3. Platform.

**1 Base:** The base is an assembly consisting of these parts:

The base has these parts:

- A compartment attached to the right side of the base which contains:
  - Base control console
  - Electrical panel
  - Engine
  - 12V starter battery
- A compartment attached to the left side of the base which contains:
  - A hydraulic tank with a sight gauge
  - A fuel tank with a fuel gauge
  - Hydraulic manifolds.
  - An emergency-lowering system.
  - A liquid propane gas (LPG) tank (optional equipment).
- A ladder at the rear of the base.
- Two front and two rear outriggers (optional equipment).

- Two front wheels driven by hydraulic wheel motors. The front wheels are steered by a hydraulic cylinder.
- Two rear wheels driven by hydraulic wheel motors.
- A hydraulic pump which gives power to the hydraulic system. It is connected to the engine.

**2 Lift mechanism:** The lift mechanism is a scissor-type assembly made of formed steel or tube sections. The scissor assembly and the platform are raised and lowered by single-acting hydraulic-lift cylinders with holding valves.

**3 Platform:** The platform has these parts:

- A tubular support frame
- A slip-resistant “diamond plate” deck surface
- Hinged tubular guardrails, with mid-rails and toe boards
- A spring-returned gate with a latch
- A front extension platform
- A platform control console
- An AC power outlet.

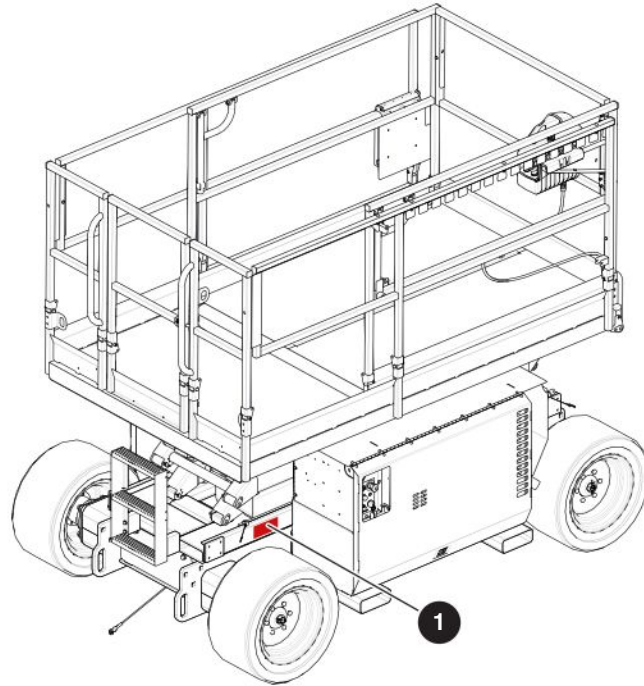

### 1.3 Serial number nameplate

The **serial number nameplate 1** is located on the side of the MEWP. It contains this information:

- Model number
- Type
- Group
- Serial number
- Indoor or outdoor use
- Capacity and maximum number of persons
- Voltage
- Maximum drive height
- Maximum platform height
- Maximum wind speed
- Maximum manual force
- Model year
- MEWP weight
- System pressure
- Maximum incline.

## 1.4 Maintenance responsibility

### 1.4-1 Operator

Before each shift starts, do all the daily inspections and function tests. Refer to [section 4](#).

### 1.4-2 Maintenance and inspection schedule

Refer to the service manual for frequent, periodic, and annual inspections.

The actual operating environment of the MEWP may affect the maintenance schedule.

### **IMPORTANT**

**Only use original or manufacturer-approved parts and components for the MEWP.**

### **NOTE**

Refer to the Skyjack website ([www.skyjack.com](http://www.skyjack.com)) for machine registration and latest service bulletins before you do frequent, periodic or annual inspections.

### 1.4-3 Owner

The owner is responsible for the maintenance inspections and repairs. Refer to the service manual for the maintenance instructions, the recommended intervals and inspection areas. Keep a record of the annual inspection on the label on the scissor assembly. Refer to [section 7.2](#) in this manual.

### **WARNING**

**Only trained and qualified/competent personnel, who understand the mechanical procedures, may do maintenance on the MEWP. The use of a MEWP that is not properly maintained or in the correct working condition could result in death or serious injury.**



# Section 2 – General Safety Precautions

## **WARNING**

Failure to obey the instructions and precautions in this manual could result in MEWP damage, property damage, personal injury, or death.

It is mandatory that you use this MEWP correctly. Read this manual and make sure you fully understand it before you operate the MEWP.

Use personal protective equipment (PPE) to protect your eyes, ears, hands, feet, and body when you do work on or near machinery.

Any modifications to the MEWP must have written permission from Skyjack.

## **WARNING**

Do not operate the MEWP if:

- It does not operate correctly
- It is damaged or shows worn or missing parts
- The safety devices are tampered with or disabled
- It is locked and tagged for servicing or repair
- It was modified without permission from Skyjack and the MEWP owner.

If you do not obey, there is a risk of death or serious injury.

## 2.1 Electrocuting hazards

The MEWP is not electrically insulated and does not provide protection from contact with or proximity to energized electrical conductors. Follow [section 2.1-1](#) for the minimum distance to keep between all parts of the MEWP, occupants, or tools, and the electrical conductors. Consider MEWP movement and electrical line sway in minimum distance calculation.

If you need to work nearer than 3 m (10ft), stop and apply control measures as determined by a qualified person with respect to electrical transmission and distribution.

Obey all the national, state/provincial/territorial and local safety rules.

### 2.1-1 Minimum distance from electrical conductors

Voltage Range	Minimum Distance from Electrical Conductors
≤ 50 KVA	3 m (10 ft)
> 50 KVA, or if not known	STOP and apply control measures as determined by a qualified person with respect to electrical transmission and distribution.

## **DANGER**

Electrocution hazard. Keep all parts of the MEWP, occupants, or tools a safe distance away from power lines, electrical power sources, or energized sources. If you do not obey, there is a risk of death or serious injury.



Keep a minimum safe distance from sources of high-voltage power.



**DO NOT** operate the MEWP during lightning or storms.

## **CAUTION**

**DO NOT** use the MEWP as a ground for welding. If you do not obey, there is a risk of minor or moderate injury, or malfunction or damage to the MEWP.

## 2.2 Safety instructions

### WARNING

**DO NOT** operate this MEWP without proper authorization and training. Failure to avoid this hazard could result in death or serious injury.

### WARNING

**DO NOT** operate this MEWP in enclosed areas without sufficient ventilation for exhaust gas and fumes. If you do not obey, there is a risk of death or serious injury.

### WARNING

Failure to heed the following safety precautions could result in tip-over, falling, crushing, or other hazards leading to death or serious injury.

KNOW all national, state/provincial or territorial, and local rules which apply to your MEWP and worksite.

MAKE SURE all the safety and instructional labels are correctly attached on the MEWP in the correct location. Clean or replace labels that you cannot read.

PREVENT unauthorized use. Disconnect and lock out main power disconnect on the left side of the MEWP when leaving the MEWP unattended.



**DO NOT** wear jewelry or loose clothing that could become caught or entangled.



**DO NOT** allow the entanglement of ropes, cables or hoses with the MEWP, adjacent structures or objects.



**Prevent falls from the platform.** Always keep a firm footing on the platform floor when working thereon. Do not climb on the toe-board, mid-rail, or top-rail. Do not use planks, ladders, or any other devices on the platform for achieving additional height or reach.



**DO NOT** raise the platform or operate elevated in windy or gusty conditions that exceed the limits specified in [section 7.4](#).



**DO NOT** increase the surface area of the platform or carry large surface area items when exposed to wind. Increasing the area exposed to the wind will decrease the MEWP stability.



**DO NOT** elevate or drive elevated on a slope. Elevated driving must be done on a firm, level surface.



**DO NOT** drive elevated on a soft or uneven surface.

**DO NOT** raise the platform if it is not on a firm, level surface.

**MAKE SURE** the ground condition assessment considers the subsurface voids such as cellars, basements, culverts, and pipes.





**DO NOT** drive elevated near depressions or holes of any type, loading docks, debris, drop-offs or surfaces that may affect the stability of the MEWP. IF OPERATION IN AREAS WITH HOLES OR DROP-OFFS IS ABSOLUTELY NECESSARY, elevated driving shall not be allowed. Position the MEWP horizontally only with the platform fully-lowered. After ensuring that all 4 wheels or outriggers (optional equipment) have contact with a firm, level surface, the platform can be raised. After elevation, the drive function must not be activated.

**DO NOT** ascend or descend grades greater than the maximum inclines listed in [section 7.3](#). Ascending or descending slopes must only be done when fully lowered.



**DO NOT** operate a MEWP that has ladders, scaffolding, or other devices on it to increase the platform size or work height.



**DO NOT** exceed the maximum side force shown on the capacity label when the platform is elevated. Refer to [section 7.4](#).



**DO NOT** use the MEWP as a crane.



**DO NOT** sit, stand, or climb on the guardrails.



**DO NOT** climb on the scissor arm assembly.



**DO NOT** collide or crush. Be aware of obstructions, personnel, or other possible hazards around the MEWP when elevating, lowering, or driving. Keep all body parts inside the platform when elevating or driving. Be aware of blind spots when operating the MEWP.



**DO NOT** elevate the platform when the MEWP is on a truck, forklift, or other device or vehicle.



**DO NOT** use the MEWP when the wheels or tires are damaged. Make sure the wheel nuts are tight. Refer to [section 4.2-5](#).



**DO NOT** alter or disable limit switches or other safety devices.



**DO NOT** use the MEWP without guardrails, locking pins, and the entry gate(s) in place.



**DO NOT** use the MEWP under the influence of alcohol or drugs, or if the operator's performance is impaired by a medical condition, the influence of prescription or over-the-counter drugs, or fatigue.



**DO NOT** exceed the rated capacity of the MEWP.



**DO NOT** distribute the load unevenly.



**DO NOT** use the MEWP if it does not function correctly or if any parts are damaged or worn.



**DO NOT** leave the MEWP unattended with the key in the key switch.

**DO NOT** operate on slippery surfaces without sufficient traction to stop, drive, or steer the MEWP.

**STUNT** driving and horseplay are prohibited.

**DO NOT** position the MEWP against another object to steady the platform.

**DO NOT** place materials on the guardrails or materials that exceed the confines of the guardrails unless approved by Skyjack.

Remove all personnel from the platform before you try to free a snagged platform with the base controls.

## 2.3 Fall-protection

The guardrail system is the primary fall-protection system of the MEWP platform.

If personal fall-protection equipment (PFPE) is required, by an employer or the authority having jurisdiction, Skyjack recommends the use of a full body harness with a lanyard. PFPE must be attached only to approved fall-protection anchorage points in the platform.

All PFPE must be compliant with applicable government rules and must be inspected as per the manufacturer's recommendation.

Use the three points of contact principle when you enter or exit the platform. This is when two hands and one foot, or one hand and two feet are in contact with the MEWP or the ground at all times.

### **WARNING**

#### Fall hazard.

- **Only enter and exit the MEWP using the three points of contact principle.**
- **Only use the equipped access openings.**
- **Only enter and exit the MEWP when the platform is fully lowered.**
- **Face the MEWP when entering or exiting the platform.**

**Failure to follow these instructions could result in death or serious injury.**

## 2.4 Worksite inspection

Make sure the operating environment, ambient temperature, Electromagnetic Compatibility (EMC), and Hazardous Location Rating (locations with potentially flammable gases, explosive gases or particles) are appropriate for the MEWP specifications (refer to [section 7.5](#)).

Be sure to follow all national, state/provincial/territorial, and local rules that relate to operating the MEWP.

Perform a full worksite inspection before operating the MEWP. Identify potential hazards in the area.

Be aware of moving equipment in the area. Take the necessary precautions to prevent collisions.

It is the responsibility of the operator to perform a worksite inspection and avoid/address the following hazards:

- Holes or drop-offs
- Slopes
- Ditches or soft fills
- Floor obstructions, bumps, or debris
- Overhead obstructions
- Electrical conductors
- Hazardous locations
- Inadequate surface support to withstand all load forces imposed by the MEWP (refer to [section 7.6](#))
- Wind and weather conditions
- Presence of personnel
- Other mobile equipment
- Traffic hazards
- Equipment that could move and collide with the MEWP, such as overhead cranes
- Other possible unsafe conditions.



---

## Section 3 – Familiarization

### **WARNING**

Do not operate this MEWP without correct training and authorization. If you do not obey, there is a risk of death or serious injury.

---

### **WARNING**

MEWP Familiarization must be given to a qualified operator. If you do not obey, there is a risk of death or serious injury.

---

### **WARNING**

It is the responsibility of the operator to fully understand, and follow all instructions and warnings contained in this operation manual and on the MEWP. If you do not obey, there is a risk of death or serious injury.

---

Read and fully understand the operation manual, all the warnings, and the instruction labels (refer to [section 8](#)) on the MEWP.

Do these tasks before the operation:

1. Worksite inspection. Refer to [section 2.4](#).
2. Daily visual and maintenance inspections. Refer to [section 4.2](#).
3. Function tests. Refer to [section 4.3](#).

### 3.1 Overview of the MEWP

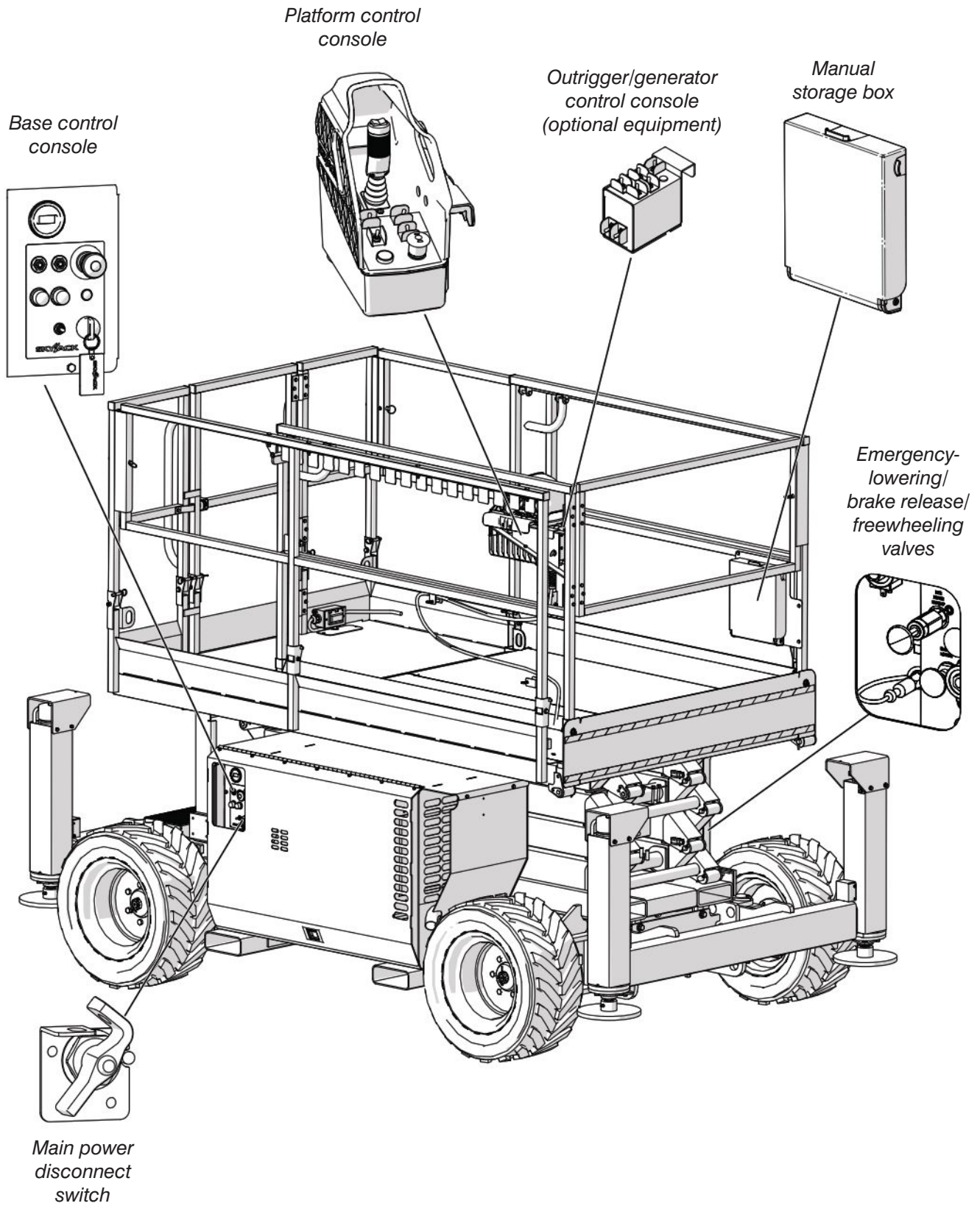

## 3.2 Manual storage box

The manual storage box is weather-resistant. It contains the operation manual, ANSI Manual of Responsibilities, and the ANSI/CSA certificate and other important documents. You must keep the operation manual and other important documents related to the MEWP in this box. Refer to [section 3.1](#) for the location of the manual storage box.

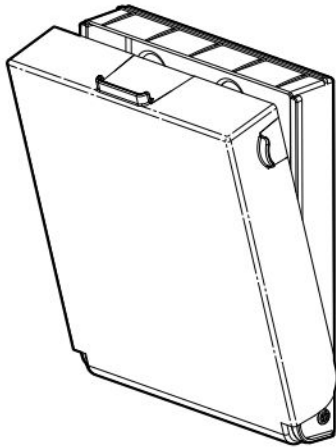

## 3.3 Control functions

### 3.3-1 Main power disconnect switch

Refer to [section 3.1](#) for the location of the main power disconnect switch.

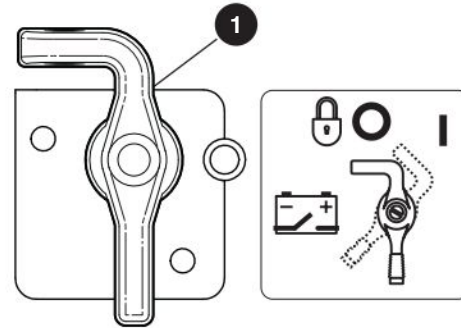

- 1 Main power disconnect:** This switch disconnects power to all control circuits when it is in the off position. The switch must be in the on position to operate the MEWP. The switch must be in the off position when you transport the MEWP or put it in storage.



### 3.3-2 Base control console

Refer to [section 3.1](#) for the location of the base control console.

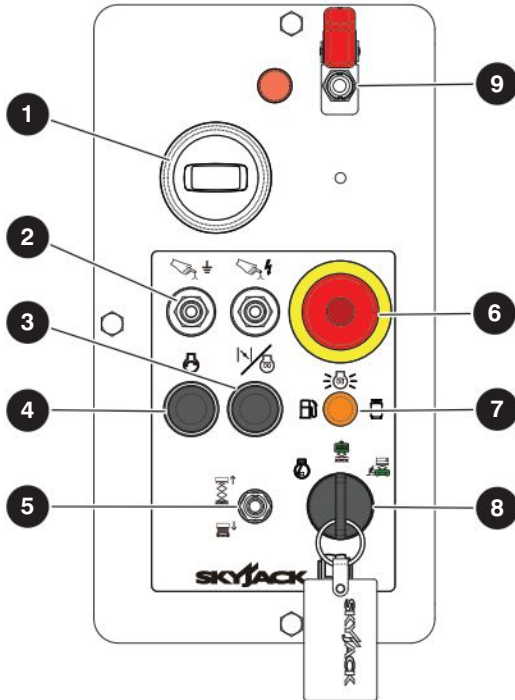

- 1 **Hour meter:** This gauge records the total operation time of the engine.
- 2 **Circuit breaker:** If a power overload or positive circuit grounding occurs, the circuit breaker comes out. Push the **circuit breaker** in to reset the power.
- 3 **Choke/glow plug:** Push and hold this button to help start a cold dual-fuel (choke) or diesel (glow plug) engine.
- 4 **Engine start:** This push-button starts the engine.
- 5 **Lower/off/raise:** This switch controls the platform lower or raise function.
- 6 **Emergency-stop:** This button disconnects power to the control circuit. Pull to connect the power again.
- 7 **Fuel selector (dual fuel):** Use this switch to select liquid propane gas (LPG) or gasoline as the fuel type.

**Glow plug indicator (diesel):** This light comes on when the glow plug switch is held. It stays on until the glow plug heating cycle is complete.

- 8 **Idle/platform/base key:** With this three-way switch, you can:
  - Turn the engine to Idle mode.
  - Energize the base controls.
  - Energize the platform controls.
- 9 **Positive air shutoff (optional equipment):** This switch stops the air supply to the engine. This is useful if the engine does not immediately stop when the power is off.



### 3.3-3 Platform control console

Use this control console to operate the MEWP from the platform or the ground. To operate the MEWP from a position on the ground, refer to [section 6.5](#).

Refer to [section 3.1](#) for the location of the platform control console.

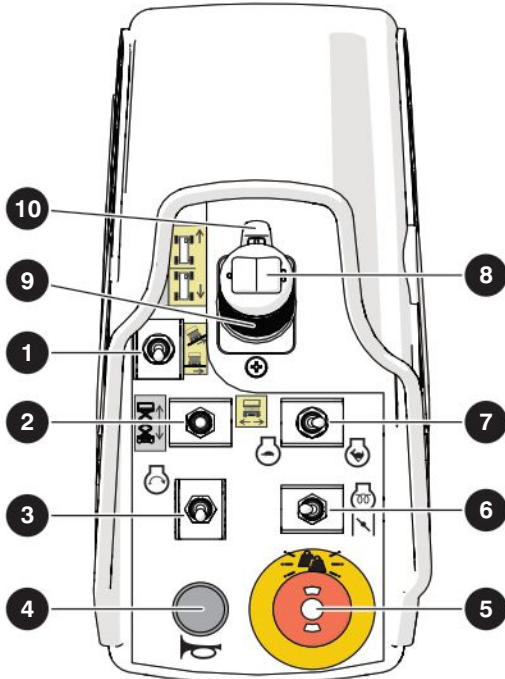

- 1 **Inclined drive/level drive:** This switch selects the inclined drive (low speed/high torque), or the level drive (high speed/low torque).
- 2 **Lift/off/drive:** This switch has three positions or modes.
  - The off position on this switch disconnects the power to both the lift and drive circuits.
  - The lift position energizes the lift circuit.
  - The drive position energizes the drive circuit.
- 3 **Engine start:** This switch starts the engine.  
If the engine stalls or does not start immediately, wait two or three seconds for the oil pressure to bleed off and try again.
- 4 **Horn:** This push-button makes a sound like a car horn.
- 5 **Emergency-stop/operation light:** This button disconnects power to the control circuit.
  - When the light is on continuously, the platform controls are available.
  - When the light flashes, there is an overload (refer to [section 3.4-8](#))

- 6 **Choke/glow plug:** Push and hold this button to help start a cold dual fuel (choke) or diesel (glow plug) engine.
- 7 **Low/high throttle switch:** This switch selects between low and high engine throttle speeds.
- 8 **Steering rocker:** This switch controls the left and right steering. Release the switch to return it to the neutral position.
- 9 **Lift/drive controller:** This one-hand lever controls the lift and drive movements. Release the controller to return it to the initial neutral position.
- 10 **Lift/drive/steer function-enable:** This switch energizes the controller handle. Squeeze and hold the switch continuously to engage the lift, drive and steer.

## 3.4 Features and devices

### 3.4-1 Lowered travel position and elevated travel position

The available MEWP functions depend on these factors:

- MEWP configuration (lowered travel position/ elevated travel position)
- Chassis angle
- Platform load.

The MEWP is in the lowered travel position when the platform is below height “A” (refer to [section 3.1](#)).

The MEWP is in the elevated travel position when the platform is at or above height “A” (refer to [section 3.1](#)).

When the platform is above the maximum drive height, the drive function does not work (refer to [section 3.1](#)).

Model	A - Height	Maximum drive height
SJ6826 RT	< 2.13 m (7 ft)	Full height
SJ6832 RT	< 2.13 m (7 ft)	Full height

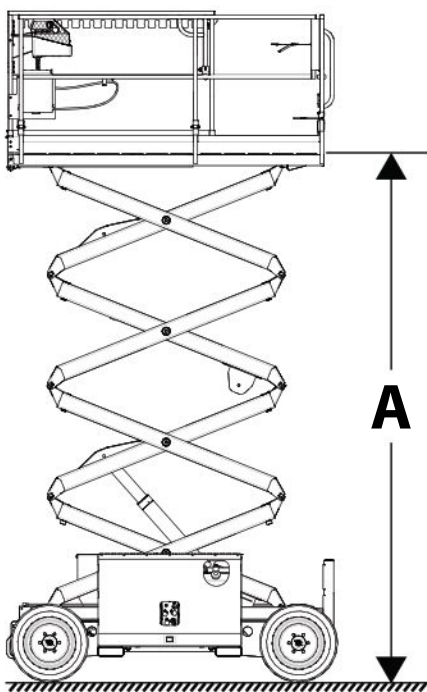

Figure 01 Lowered and elevated travel position

### 3.4-2 Drive speed

The drive speed depends on the MEWP configuration. When the MEWP is in the elevated travel position, the speed is slower than when it is in the lowered travel position. Refer to [section 7.3](#).

### 3.4-3 Tilt switch

This device senses when the MEWP has passed a predetermined angle in the longitudinal (front-to-back) or lateral (side-to-side) direction (refer to [section 7.4](#)). When the tilt switch is on, and the MEWP is in the elevated travel position, it disables the drive and lift functions. An alarm makes a sound and an amber light on the lower cross member flashes. If the alarm makes a sound, fully lower the platform. Level the MEWP before you raise the platform.

### 3.4-4 Brake release system

This system disengages the brakes manually before you push, winch, or tow the MEWP. Refer to [section 6.2](#) for the procedure. Refer to [section 3.1](#) for the location of the brake-release system.

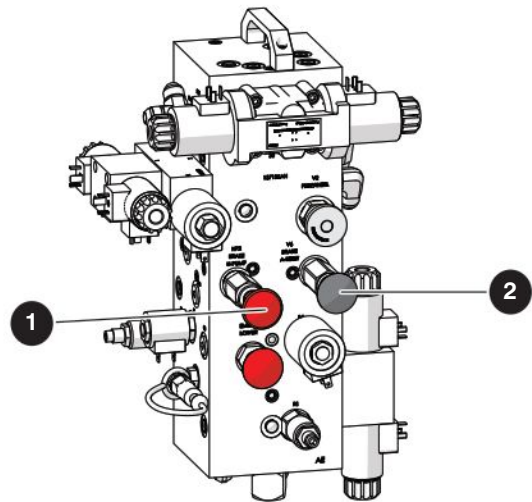

- 1 Brake hand pump
- 2 Brake auto-reset valve plunger

### 3.4-5 Freewheeling valve

Refer to [section 6.2](#) for the procedure on how to release the freewheeling valve.

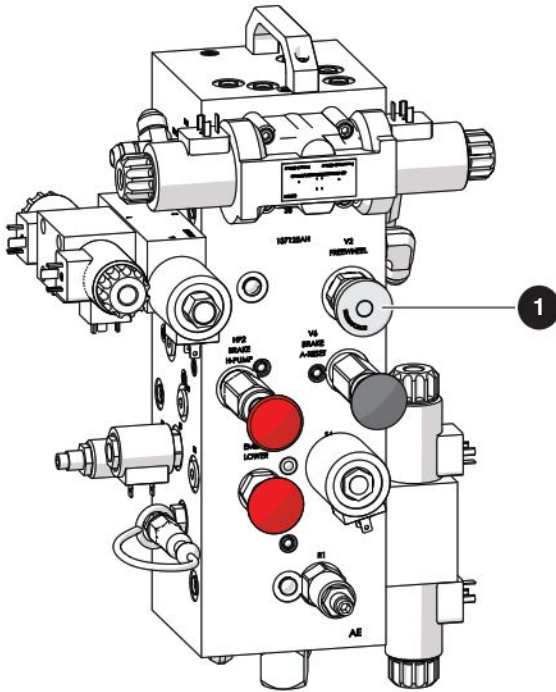

**1** Freewheeling valve

### 3.4-6 Emergency-lowering system

With the emergency-lowering system, you can lower the platform if there is a failure of the primary power. Refer to [section 6.1](#) for the emergency-lowering procedure.

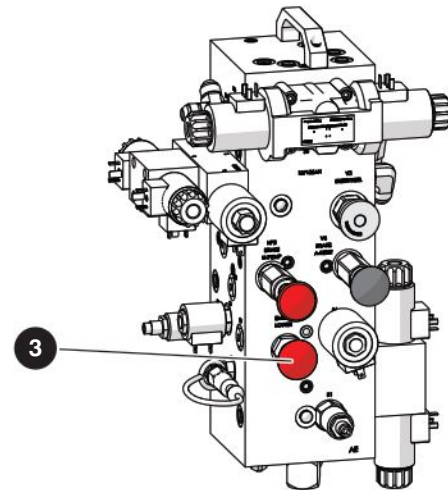
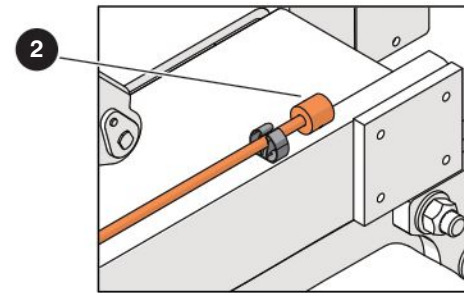
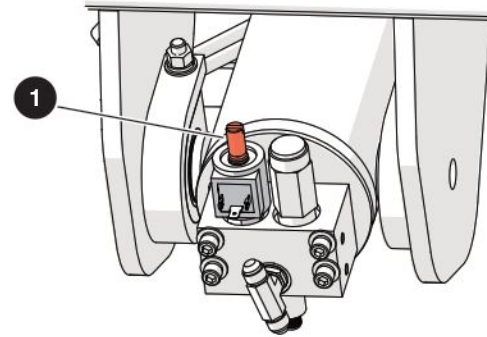

- 1** Holding-valve manual override knob
- 2** Emergency-lowering access rod
- 3** Emergency-lowering valve

### 3.4-7 Fall-protection anchorage

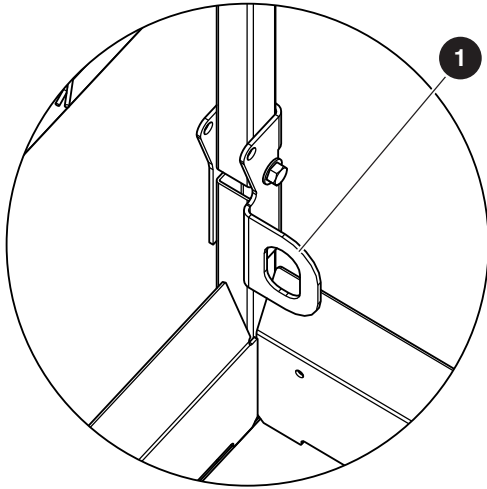

**1 Fall-protection anchorage:** When required, use this as a point to attach personal fall protection equipment (PFPE). Do not attach the PFPE to any other points on the platform. Do not use this anchorage to lift, anchor, attach, or hold the platform, or other apparatuses or material.

**⚠ WARNING**

Only use the fall-protection anchorage in the limits of the platform. Do not use the fall-protection anchorage for other than its intended function (refer to [section 2.3](#)). If you use it incorrectly, death, serious injury, and/or MEWP damage can occur.

### 3.4-8 Platform load-sensing system

The platform load-sensing system prevents normal MEWP movement when the platform is overloaded and in a stationary position. Refer to [section 7.4](#) for platform capacities.

Load status	Result
The platform is near the rated load.	The light on the emergency-stop button flashes on the platform and base control consoles. All functions are available.
The platform is at the rated load.	The alarm sounds. The light on the emergency-stop button flashes on the platform and base control consoles. All functions are available.
The load on the platform is more than the rated load.	The light on the emergency-stop button continues to flash on the platform and base control consoles. The alarm continues to sound at increased frequency. All normal MEWP movement functions are unavailable.

Remove the overload from the platform to continue the normal operation.

**⚠ WARNING**

Fall hazard. Do not try to free a snagged platform with the base controls until you remove all personnel from the platform. If you do not obey, there is a risk of death or serious injury.



### 3.4-9 Maintenance support

Use the **maintenance support** ❶ when you do an inspection of the lift mechanism or do maintenance. Refer to [section 6.8](#) for the procedure on how to use the maintenance support.

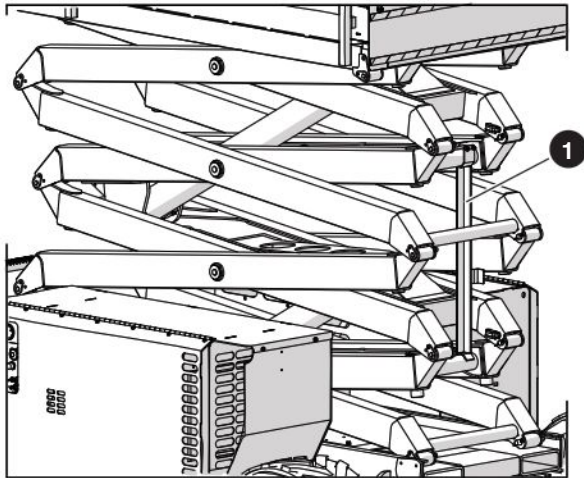

### 3.4-10 Propane cylinder

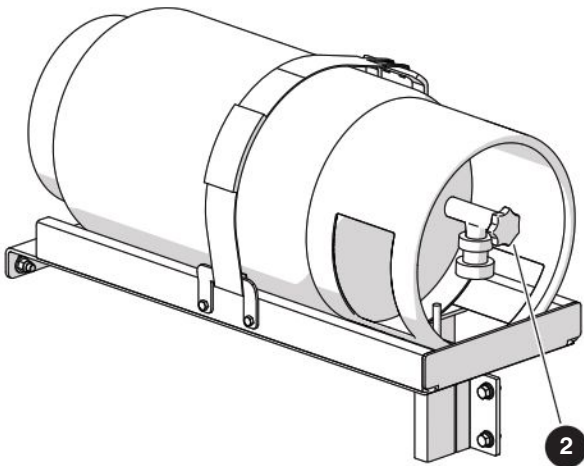

The propane cylinder is available in MEWPs with dual fuel engines.

- ❷ **Propane cylinder valve:** Turn the valve clockwise to close the fuel supply. Turn the valve counterclockwise to open the fuel supply.

### 3.4-11 Outriggers (optional equipment)

The auto-level system deploys and retracts all four outriggers at the same time. Use this system to level the MEWP from the platform.

## 3.5 General components

### 3.5-1 AC power socket on the platform

The AC power socket is a source of AC power on the platform when the plug at the base is connected to a generator or an external power supply.

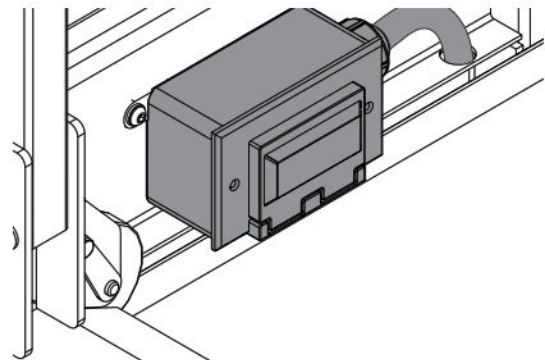

### 3.5-2 Folding guardrail system

When you fold down this system, it decreases the height of the fully-lowered MEWP to transport the MEWP and/or to drive the MEWP through doorways. Refer to [section 6.6](#) for the procedure on how to fold the guardrails.

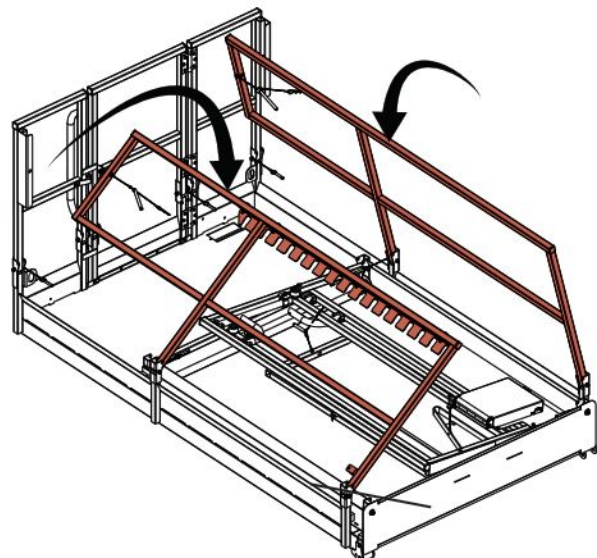

### 3.5-3 Extension platform

The extension platform increases the length and area of the platform. Refer to [section](#) on how to extend and retract the extension platform.

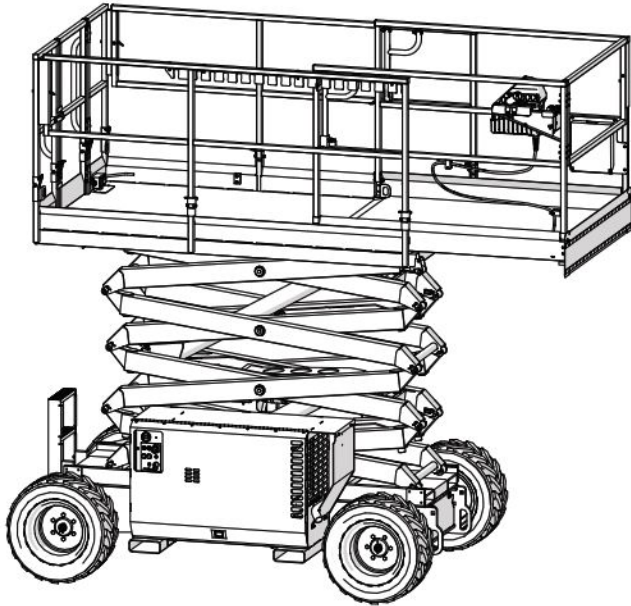

### 3.5-4 Motion alarm

The alarm makes a sound when a control function operates. On some MEWPs, an amber flashing light goes with this alarm.

## 3.6 Optional equipment

### ⚠ CAUTION

Skyjack approved modifications and attachments can change the MEWP specifications. Refer to the applicable instructions and labels.

### IMPORTANT

Refer to the labels of the optional equipment for the actual weight. Include this weight to calculate the total load on the platform. Include personnel and other materials in the total load.

The weight of the attached parts, panels, occupants, and tools put together must not be more than the rated platform capacity.

### 3.6-1 Secondary Guarding Lift Enable (SGLE) push-button

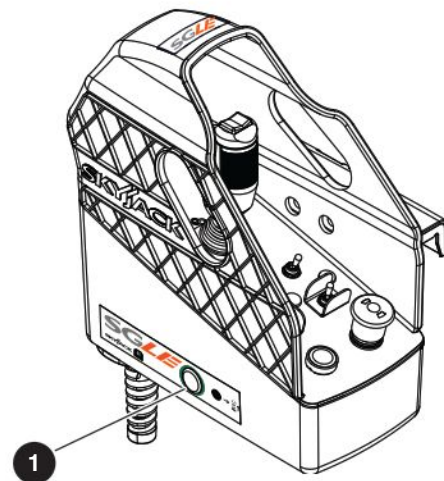

- ① **SGLE:** This push-button energizes the lift function. Hold the button down together with the function-enable switch to enable the raising of the platform with the lift function.

### NOTE

The SGLE does not have an effect on these functions: lower, drive, steer, auto-level, or emergency-lowering.

### 3.6-2 Elevate™ telematics - access control unit

Access control is an added function of the Elevate™ telematics. The access control unit will allow the electric motor to operate only with an approved code or card. However, it does not have an effect on: emergency lowering, load sensing, the hor, and when you lower the platform. These functions are always available.

#### IMPORTANT

**The owner is responsible to supply PIN codes or Smart ID cards for MEWPs that have the access control function. Skyjack does not supply or reset PIN codes or Smart ID cards. Speak to the MEWP owner to help you with PIN codes or Smart ID cards that do not function, or you cannot find.**

With the access control function, the user can control access to the MEWP operation. You can get unique PIN codes or Smart ID cards to unlock and start the MEWP. For this function, an Elevate™ telematics device and an access control keypad are necessary. With the Trackunit Manager, the MEWP owner can customize the access control to the MEWP (<https://www.trackunit.com/services/manager/>). Speak to the MEWP owner to help you with PIN codes or Smart ID cards that do not function, or you cannot find.

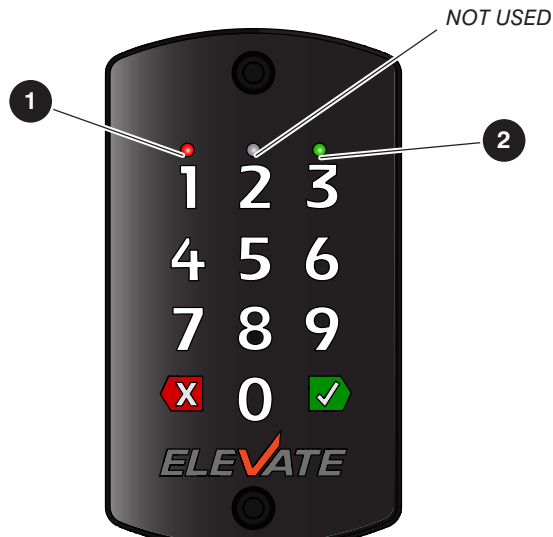

Figure 02 Keypad of the access control unit

**1 Orange indicator:** This light shows that the access control unit is ON. The keypad always has power regardless of the emergency-stop, idle/platform/base key switch, or main power disconnect position.

**2 Green/red indicator:** A green light shows that the access control unit is in operation. A red light that flashes shows that the keypad received a cancel input.

#### Operation

To operate the MEWP, the light and all of these power connections must be ON before the set time expires. This set time is the time that the MEWP owner sets for the access control operation.

- The green light on the keypad of the access control unit.
- The main power disconnect switch.
- The emergency-stop button on the base control console.
- The idle/platform/base key switch.

You can also set these power connections to ON before you start the access control unit.

To operate the access control unit, use the PIN code or Smart ID card.

#### With the Keypad:



#### NOTE

*This touch-sensitive keypad beeps to identify a correct input.*

1. Enter the PIN code.
2. Press the **green checkmark** to confirm.
  - **Result:** The green light identifies an approved ID. Start the operation.



#### NOTE

*If you push an incorrect button when you enter the PIN code, push the Cancel button to start again.*

#### With the Smart ID Card:

1. Hold the Smart ID card in front of the reader.
  - Result:** A beep identifies that the reader read the card. The green light identifies an approved ID. Start the operation.

**IMPORTANT**

To start the access control unit, enter the PIN code or tap the SMART ID card. The access control unit will not operate if these power connections are not in the on position in the set time or if the operator disconnects them:

**The main power disconnect switch**

- The emergency-stop button on the base control console
- The off/platform/base key switch.

**IMPORTANT**

To start the access control unit, enter the PIN code or tap the Smart ID card. These power connections must be in the ON position in the set time:

- The main power disconnect switch
- The emergency-stop button on the base control console
- The idle/platform/base key switch.

**Function Tests**

Do the function tests as specified in [section 4.3](#).

When you do the function tests, make sure that the green light on the keypad is ON. This light confirms that the access control unit is in operation. Do the function tests for these power connections in the set time:

- The main power disconnect switch
- The emergency-stop button on the base control console
- The idle/platform/base key switch.

**3.6-3 Outrigger/generator control console**

The auto-level system deploys and retracts all four outriggers at the same time. Use this system to level the MEWP from the platform.

The outrigger control console is next to the platform control console. The switches on the outrigger control console control the extension and retraction of the outriggers.

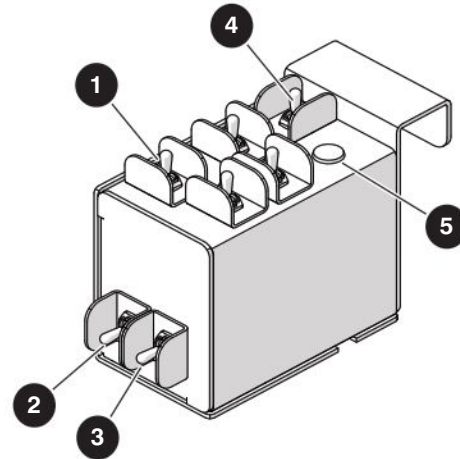

- 1 **Outrigger extend/retract:** These switches control the extension and retraction of each outrigger.
- 2 **Auto-level:** In the extend position, each outrigger extends and automatically adjusts until the MEWP is level. In the retract position, the outriggers retract.
- 3 **Outrigger enable:** When in the extend or retract position, this switch enables functions of the auto-level switch and outrigger extend/retract switches.
- 4 **Generator switch:** This switch turns the generator on or off.



- 5 **Auto-level light:** This light illuminates to show the status of the outriggers when the automatic and manual level functions are in use. The light has these states:

Auto-level light	Outrigger condition
Off	The outriggers are fully retracted. The outriggers are not active.
Flashing slowly	Indicates the outrigger extension or retraction.
Flashing quickly	The outriggers are extended and the MEWP is not level, or there is an outrigger or auto-level function error.
On	The outriggers are extended and the MEWP is level. The light is on while the auto-level function is active only.

### 3.6-4 Hydraulic generator

The hydraulic generator supplies power to the AC power socket on the platform of the MEWP.

It is controlled by the generator switch on the outrigger control console.

Refer to [section 5.11](#) on how to operate the hydraulic generator.



---

# Section 4 – Inspections Before Operation

## 4.1 Operator's Responsibility

Do these tasks before each work shift and in this sequence:

1. **Visual and daily maintenance inspections**  
(refer to [section 4.2](#)).

### **WARNING**

**Do an inspection on the MEWP for damage or loose or missing parts. If damage is found, lock and tag the MEWP and remove it from service. If you do not obey, there is a risk of death or serious injury.**

2. **Function tests** (refer to [section 4.3](#)).

Refer to [section 4.4](#) for a checklist of the inspection items.

### **WARNING**

**If the MEWP is damaged or has been modified from the initial factory-delivered condition, without permission from Skyjack, lock and tag the MEWP. Remove the MEWP from service. If you do not obey, there is a risk of death or serious injury.**

Repairs to the MEWP are tasks only for a qualified service technician. Do the visual and daily maintenance inspections and function tests again after the repairs.

Scheduled maintenance inspections are a task only for a qualified service technician.

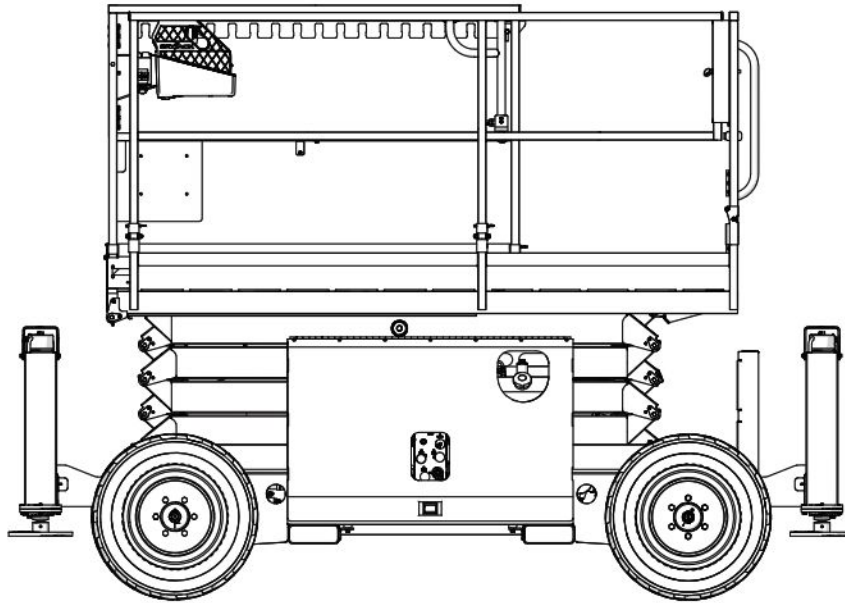

## 4.2 Visual and daily maintenance inspections

Do an inspection of the MEWP in this sequence.

### **CAUTION**

Make sure that the MEWP is on a firm, level surface before you do the visual and daily maintenance inspections. If you do not obey, there is a risk of machine damage.

### **WARNING**

Turn the main power disconnect switch to the off position before you do the visual and daily maintenance inspections. If you do not obey, there is a risk of death or serious injury.

### **WARNING**

Do not operate a MEWP that does not function correctly. Lock and tag the MEWP, and remove it for servicing. Only a qualified service technician must repair the MEWP. If you do not obey, there is a risk of death or serious injury.

### 4.2-1 Labels

Refer to [section 8](#) in this manual for the labels. Make sure all the labels are in the correct location, are in good condition, and you can read them.

### 4.2-2 Electrical

Do a check on these areas for chafed, corroded, and loose wires:

- Base to platform cables and wiring harness
- Engine wiring harnesses
- Hydraulic and electrical wiring harnesses.

### 4.2-3 Hydraulic

Do a check on these areas and make sure there are no signs of leakage:

- Hydraulic tank, gauge, filter, fittings, hoses
- Engine compartment fittings, hoses, primary pump, and filter
- All hydraulic cylinders
- All hydraulic manifolds
- The ground area below the MEWP
- Outriggers (optional equipment).

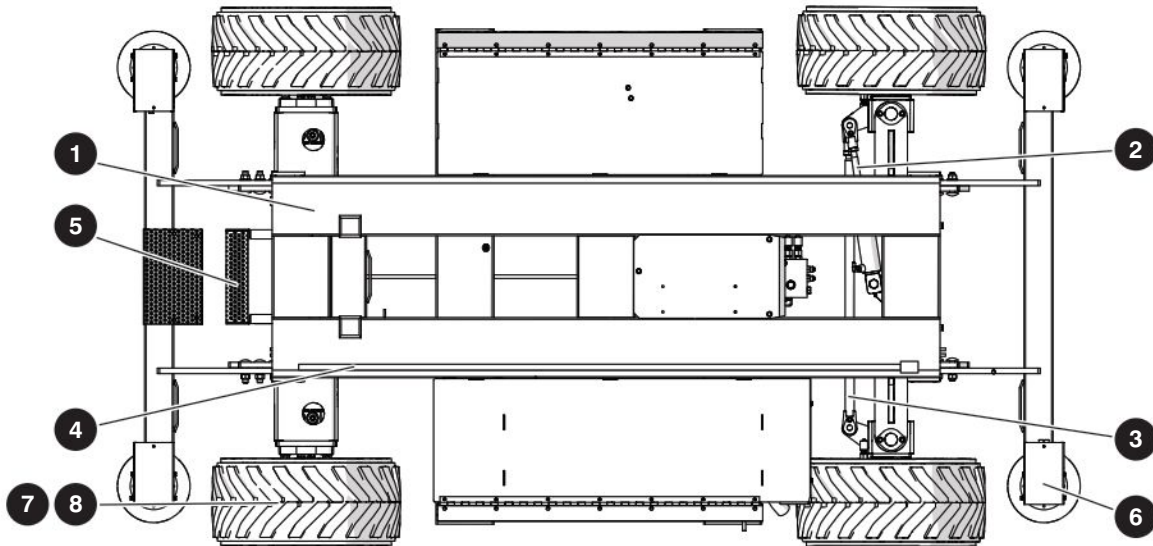

#### 4.2-4 Base

Do the inspection that follows, and make sure:

- 1 **Base weldment**
  - There are no cracks in the welds or structure.
  - There are no signs of deformation.
- 2 **Steer cylinder**
  - The steer cylinder assembly is correctly installed.
  - There are no loose or missing fasteners.
  - There is no visible damage.
- 3 **Tie rod**
  - There are no loose or missing parts.
  - The tie rod end studs are attached and tight.
  - There is no visible damage.
- 4 **Emergency-lowering access rod**
  - The rod is correctly attached and has no visible damage.
- 5 **Ladder**
  - There are no loose or missing parts.
  - There is no visible damage.
- 6 **Outriggers (optional equipment)**
  - There are no loose or missing parts.
  - There is no visible damage.

#### 4.2-5 Wheels/Tires

Do the inspection that follows:

- 7 **Wheel/tire assembly**
  - Do a check on all the tire treads and sidewalls for cuts, cracks, and unusual wear.
  - Do a check on each wheel for damage, and cracked welds.
  - Make sure the wheels are correctly aligned vertically and horizontally.
  - Make sure there are no loose or missing parts.
  - Make sure there is no visible damage.

#### **⚠ WARNING**

**Do not use tires other than the tires that Skyjack specifies for this MEWP. Do not mix different types of tires or use tires that are not in good condition. Only replace the tires with the same types that are approved by Skyjack. The use of other tires can make the MEWP less stable. If you do not obey, there is a risk of death or serious injury.**

- 8 **Wheel nuts**
  - Make sure the wheel nuts are installed and are tight.

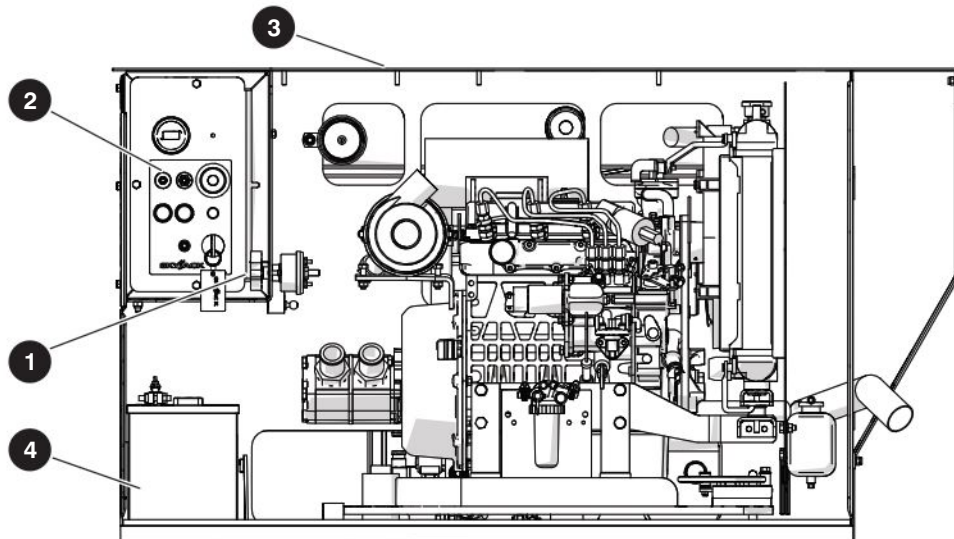

### 4.2-6 Engine compartment

Do the inspection that follows:

- 1 **Main power disconnect switch**
  - Turn the **main power disconnect** switch to the off position.
  - Make sure the switch rotates and stays in the on and off position.
  - Make sure the cables are not loose.
- 2 **Base control**
  - Make sure there is no visible damage, and all the switches are in their off/neutral positions.
- 3 **Engine compartment cover**
  - Make sure that the engine access door is latched tightly and in good condition.
  - Make sure that the hinges and lockable latch on the engine access door are latched tightly and in good condition.
  - Make sure that the hinges have sufficient lubrication.

#### **⚠ WARNING**

**Burn hazard. Do not touch hot engine components without the correct PPE. Let the engine cool before you do an inspection or servicing. If you do not obey, there is a risk of death or serious injury.**

#### 4 **Battery**

- Do an inspection of the battery case for damage.
- Make sure all the battery connections are tight.
- If applicable, check the battery fluid levels. If the plates do not have a minimum 13 mm (1/2 inch) of solution above them, add distilled or demineralized water.

#### **⚠ WARNING**

**Explosion hazard. Keep flames and sparks away. Do not smoke near the batteries. Batteries release explosive gas while you charge them. Charge the batteries in a well-ventilated area. If you do not obey, there is a risk of death or serious injury.**

#### **⚠ WARNING**

**Corrosion hazard. Do not touch battery acid. Wear the correct PPE. If the battery acid touches you, immediately flush the area with cold water and get medical aid.**

#### **⚠ WARNING**

**Only use original or manufacturer-approved parts and components for the MEWP. If you do not obey, there is a risk of death, serious injury, or machine damage.**

#### **⚠ WARNING**

**Burn hazard. Do not touch hot engine components without the correct PPE. Let the engine cool before you do an inspection or servicing. If you do not obey, there is a risk of death or serious injury.**

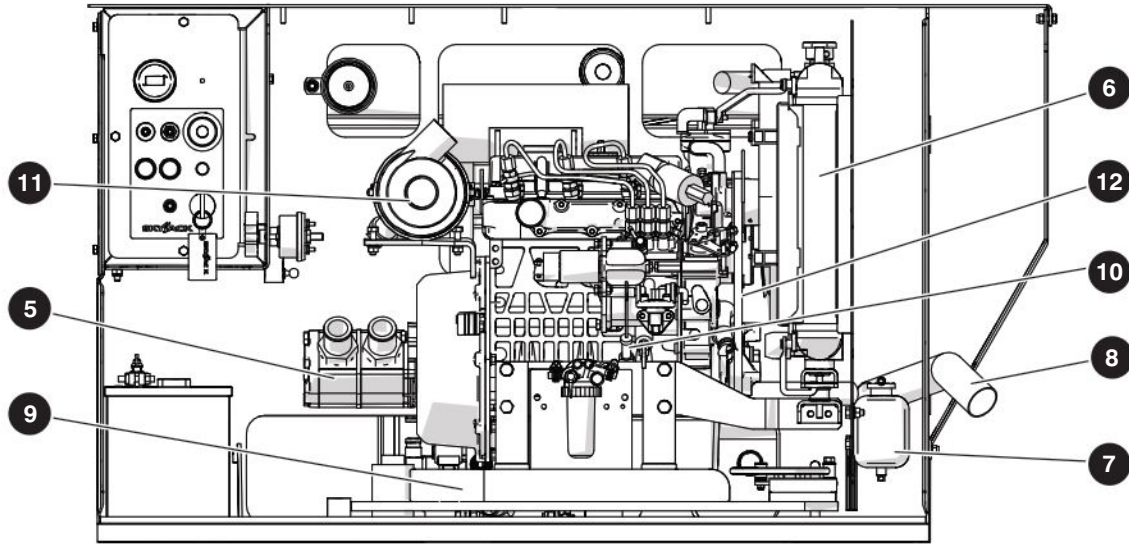

Use the handle on the engine pivot tray to move the engine out of the engine compartment.

**5 Hydraulic pump**

- Make sure that there are no loose or missing parts and no damage.
- Make sure that all bolts are tight.
- Make sure that all fittings and hoses are tight
- Make sure there are no hydraulic fluid leaks.

**6 Radiator**

- Make sure that the radiator is correctly installed.
- Make sure there are no loose or missing parts
- Make sure there is no visible damage.

**7 Engine coolant**

**⚠ WARNING**

**Burn hazard. There is pressurized fluid in the radiator. Do not open the radiator cap when it is hot. Wear the correct PPE. Let the engine cool before servicing. If you do not obey, there is a risk of death or serious injury.**

- Do a check of the coolant level. Add coolant if it is necessary.
- Make sure there are no coolant leaks.

**8 Muffler and exhaust**

- Make sure that the muffler and exhaust systems are correctly attached with no visible damage.

**9 Engine and pivot tray**

- Make sure there are no loose or missing parts.

- Make sure there is no visible damage to the engine and engine pivot tray.
- Make sure that the engine is correctly attached to the pivot tray.

**10 Engine oil level**

- Use the dipstick to check the oil level.
- The oil level must be between the marks L (low) and H (high). Add oil if it is necessary.

**11 Engine intake air filter**

- Make sure there are no loose or missing parts.
- Make sure there is no visible damage.
- Squeeze the lips of the vacuator valve to remove the dirt and dust.
- Do an inspection of the service indicator on the air cleaner. Replace the filter element if necessary.

**12 Belts**

- Make sure that the belts do not have cracks, are not frayed, and do not have chunks of material missing.

**13 Propane tank**

- Make sure that the propane tank is correctly installed to the mounting tray.
- Make sure there is no visible damage to the hoses and fittings.
- Make sure there is no visible damage to the propane tank and no indication of propane leakage.



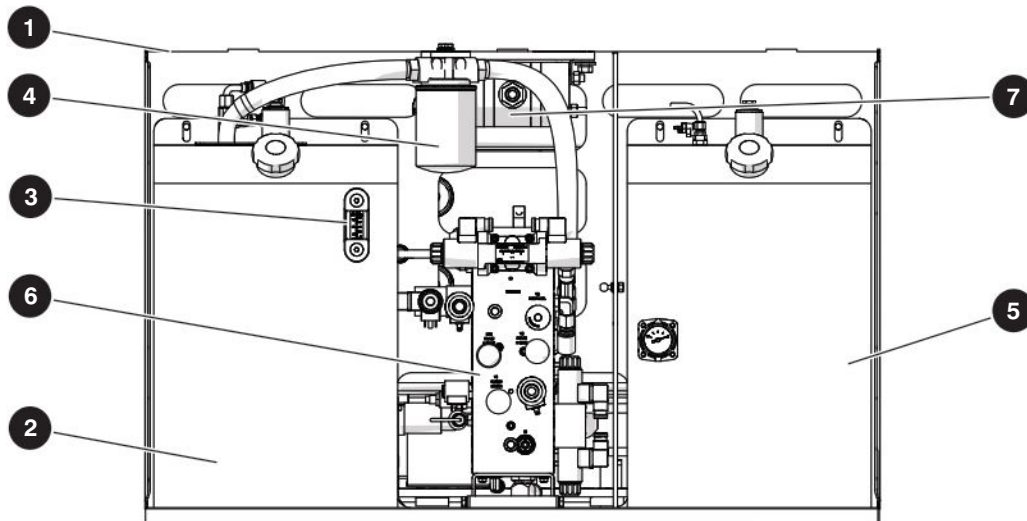

### 4.2-7 Hydraulic compartment

Do the inspection that follows:

#### **⚠ WARNING**

**Environmental hazard. Immediately remove gasoline, diesel fuel, engine oil, and hydraulic fluid spills and leaks with rags. Discard these rags in accordance with national, state/provincial/territorial, and local regulations. Spilled fluids can damage the environment. When spilled fluids go into the water (for example, a sewage system, streams, rivers, or other surface water), they can kill aquatic life.**

#### 1 Hydraulic compartment cover

- Make sure that the hinges and lockable latch on the engine access door are latched tightly and in good condition.
- Make sure that the hinges have sufficient lubrication.

#### 2 Hydraulic tank

- Make sure the hydraulic filler cap closes tightly.
- Make sure there is no visible damage or hydraulic leaks.

#### 3 Hydraulic oil level

- Make sure the platform is fully lowered and the outriggers are retracted.
- Do a check on the gauge on the front of the hydraulic oil tank. The hydraulic oil level must be at or a small distance above the top mark on the gauge.

#### 4 Hydraulic return filter

- Make sure that the filter is correctly attached.
- Make sure there is no visible damage or hydraulic leaks.

#### **⚠ WARNING**

**Explosion or fire hazard. Do not smoke near the fuel system. If you do not obey, there is a risk of death or serious injury.**

#### **IMPORTANT**

**Before you use the MEWP, make sure there is sufficient fuel for the estimated task.**

#### 5 Fuel tank

- Make sure that the fuel filler cap closes tightly.
- Make sure there is no visible damage to the tank, gauge, hoses, or fittings.
- Make sure there is no indication of fuel leakage from the tank, gauge, hoses, fittings, pump, and filter.

#### 6 Main manifold

- Make sure that all fittings and hoses are correctly tightened.
- Make sure there is no indication of hydraulic leakage.
- Make sure that there are no loose wires and no missing fasteners.

#### 7 Gear-type flow divider

- Make sure that there are no loose or missing parts.
- Make sure there is no visible damage or hydraulic leaks.



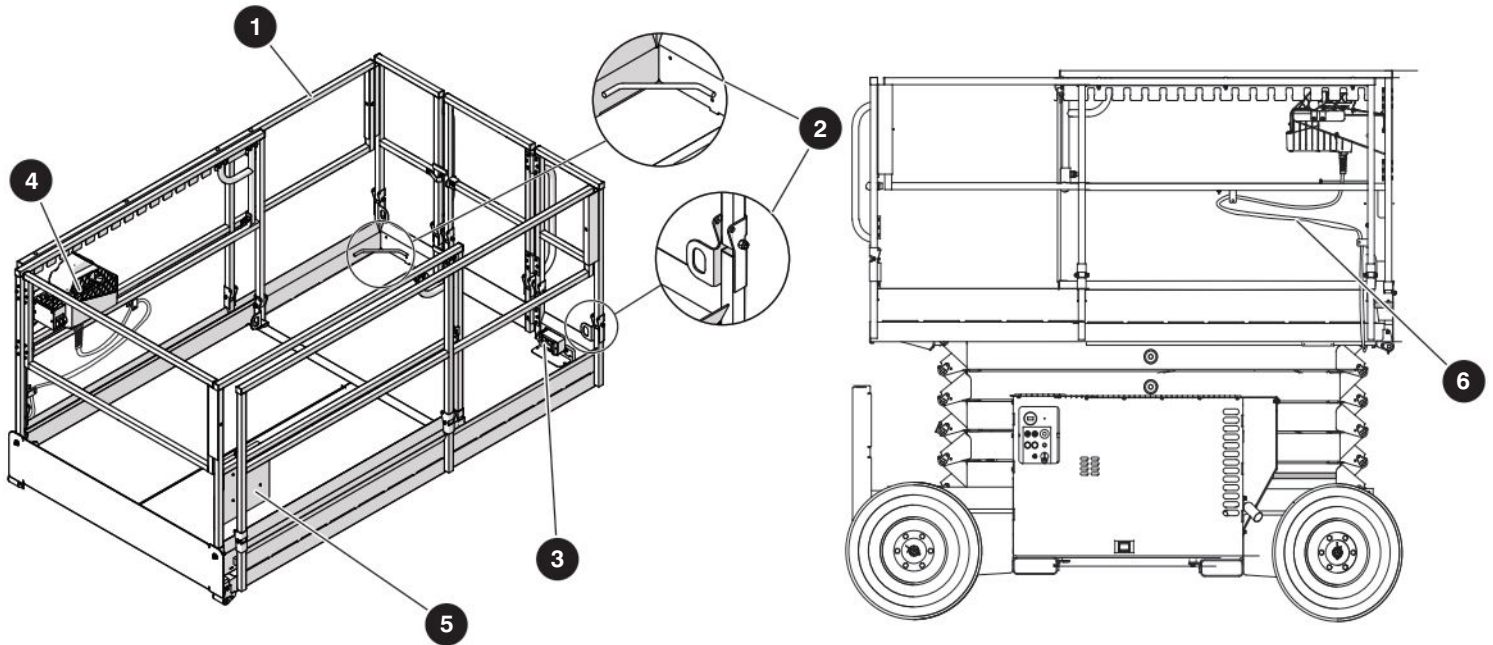

### 4.2-8 Platform assembly

Do the inspection that follows in sequence:

#### **⚠ WARNING**

**Fall Hazard. Use the three points of contact principle when you use the MEWP ladder to enter or exit the platform. If you do not obey, there is a risk of death or serious injury.**

1. Use the MEWP ladder to enter the platform.
2. Close the gate.

#### **1 Platform railings**

- Make sure there are no loose or missing parts, and there is no visible damage.
- Make sure that the lock-pins and fasteners are correctly locked.
- Make sure that the platform railings **1** are in the correct position and locked with lock-pins.
- Make sure that the gate is in good condition and operates correctly.

#### **2 Fall-protection anchorages**

- Make sure that the fall-protection anchorages are correctly installed.
- Make sure there is no visible damage.

#### **3 AC power socket**

- Make sure that the socket is free of dirt or blockages.

#### **4 Platform control console**

- Make sure that the control console is locked with lock-pins.
- Make sure that the platform control cable is correctly locked, and there is no visible damage.

#### **5 Manual storage box**

- Make sure that the operation manual and other important documents are in the manual storage box.
- Make sure that the documents are in good condition, and you can read them.
- Always put the manuals and other documents back in the storage box after use.

#### **6 Platform control cable**

- Make sure the platform control cable is correctly secured, and there is no visible damage.
- Make sure the platform control cable is correctly routed.

3. Use the MEWP ladder to exit the platform.

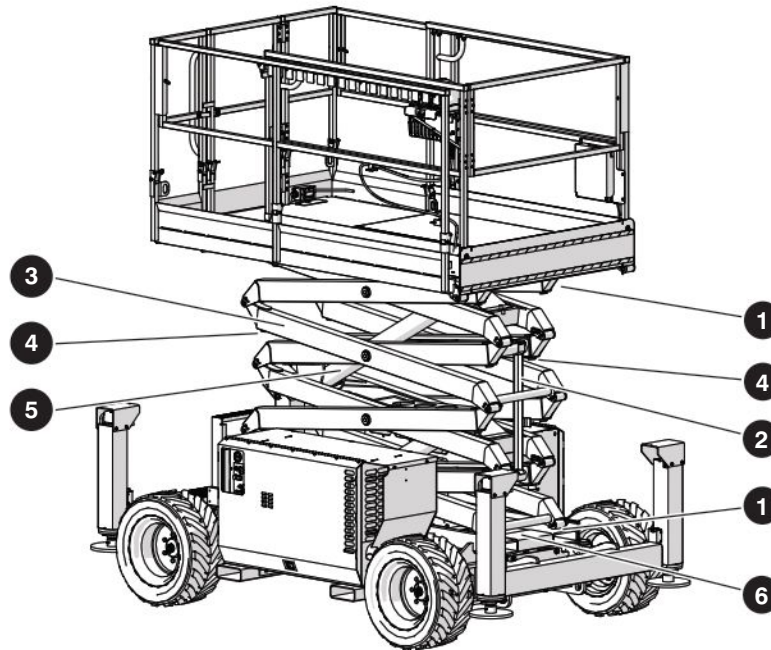

### 4.2-9 Lift mechanism

Do the inspection that follows in sequence:

#### 1 Sliders and rollers

- Make sure that the sliders and rollers on the left and right side of the MEWP are correctly attached.
- Make sure there is no visible damage.
- Make sure there is no dirt or blockages in the slider or roller paths.

1. Raise the platform (refer to [section 5.4](#)) and deploy the maintenance support (refer to [section 6.8](#)).

#### 2 Maintenance support

- Make sure that the maintenance support is correctly attached and show no visible damage.

#### 3 Scissor assembly

- Make sure that the scissor assembly shows no signs of visible damage, deformation, or cracks in the weldments.
- Make sure all the pins and fasteners are correctly installed, including the connections to the base and platform.
- Make sure that the cables and wires have the correct routing, and show no signs of wear and/or physical damage.

#### 4 Scissor bumpers

- Make sure that the bumpers are correctly attached and have no visible damage.

#### 5 Lift cylinders

- Make sure that the lift cylinders are correctly installed.
- Make sure there are no loose or missing fasteners.
- Make sure there is no indication of leaks or damage.

#### 6 Angle transducer

- Make sure that the angle transducer is correctly attached.

2. Retract the maintenance support into its storage bracket. Refer to [section 6.8](#).

3. Fully lower the platform.

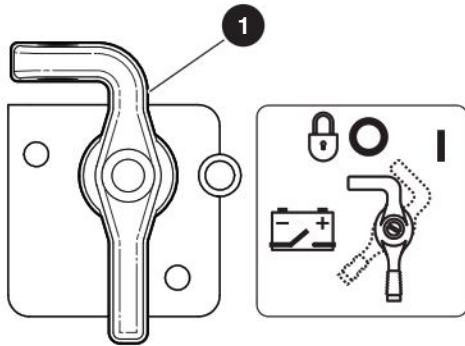

## 4.3 Function Tests

Do the function tests in sequence.

### **⚠ WARNING**

Do not operate a MEWP that does not function correctly. Lock and tag the MEWP, and remove it for servicing. Only a qualified service technician must repair the MEWP. If you do not obey, there is a risk of death or serious injury.

Be sure to read [section 5](#) before you do the function tests.

### 4.3-1 Do a test of the main power disconnect switch

1. Turn the **main power disconnect** switch **1** to the on position.
2. Pull the **emergency-stop** button on the platform control console.
3. Pull the **emergency-stop** button **2** on the base control console.
4. Turn the **idle/platform/base key** switch **3** to the **idle** position.
5. Start the engine at the base.
6. Turn the **main power disconnect** switch to the off position.
  - **Result:** The engine stops.

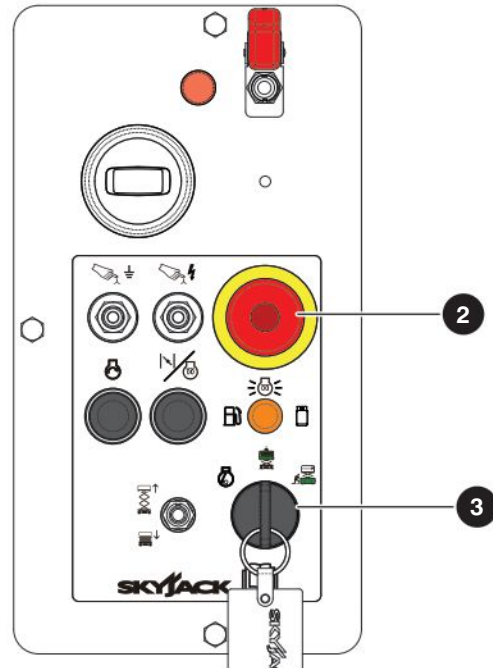

### 4.3-2 Do a test of the emergency-stop button on the base

1. Turn the **main power disconnect** switch to the on position.
2. Push the **emergency-stop** button on the base.
  - **Result:** The engine stops.

### 4.3-3 Do a test of the load-sensing module self-check

1. Push the **emergency-stop** button on the base control console.
2. Turn the **main power disconnect** switch to the on position.
3. Pull the **emergency-stop** button on the base control console.
  - **Result:** The beeper makes a sound for approximately 1 second. The light on the emergency-stop button comes on. This shows that the system is in operation, and there are no faults.

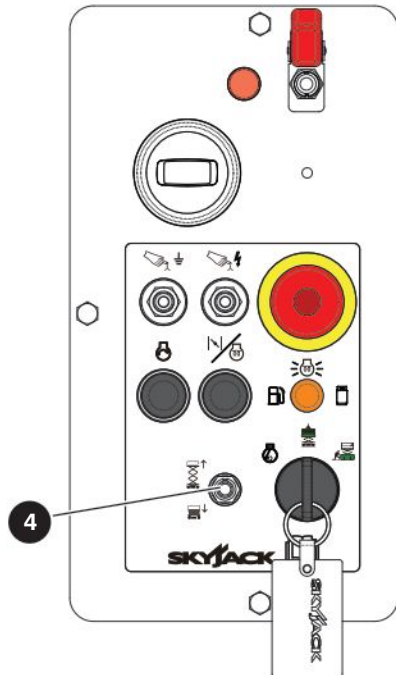

#### 4.3-4 Do a test of the idle/platform/base key switch

1. Pull the **emergency-stop** button.
2. Start the engine.

#### **WARNING**

Look for overhead obstructions or other possible hazards around the MEWP when you raise the platform. Do not lower the platform unless the area below is clear of personnel and obstructions. If you do not obey, there is a risk of death or serious injury.

3. Turn the **idle/platform/base key** switch to the platform position.
4. Move and hold the **lower/neutral/raise** switch **4** in the **raise position**.
  - **Result:** You cannot raise the platform.
5. Turn the **idle/platform/base key** switch to the base position.
6. Move and hold the **lower/neutral/raise** switch in the raise position.
  - **Result:** The platform raises.

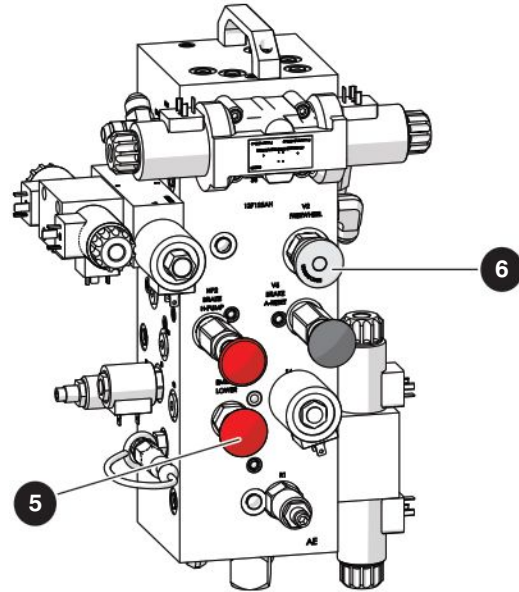

#### 4.3-5 Do a test of the emergency-lowering function

#### **WARNING**

Look for overhead obstructions or other possible hazards around the MEWP when you raise the platform. Do not lower the platform unless the area below is clear of personnel and obstructions. If you do not obey, there is a risk of death or serious injury.

1. Raise the platform.
2. Push the **emergency-stop** button on the base control console.
3. Find the **manual override knob 6** of the holding valve at the bottom of each lift cylinder.
4. Press and turn the manual override knob counterclockwise until it stops. If it is necessary, use the access rod on the base of the MEWP.
5. Pull out and hold the emergency-lowering valve **5**.
  - **Result:** The platform lowers.
6. Press and turn the manual override knob of the holding valve clockwise until it stops to restore normal operation.

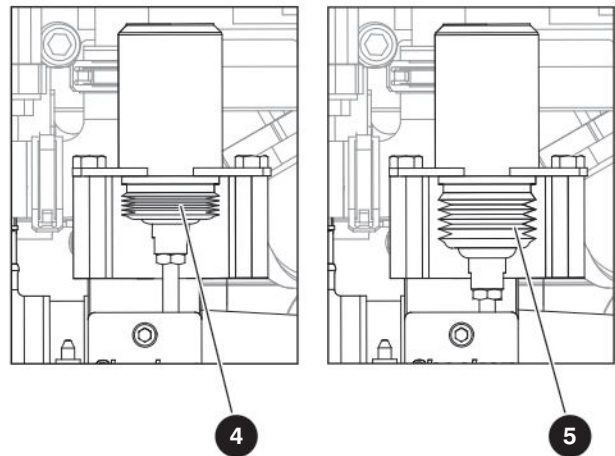
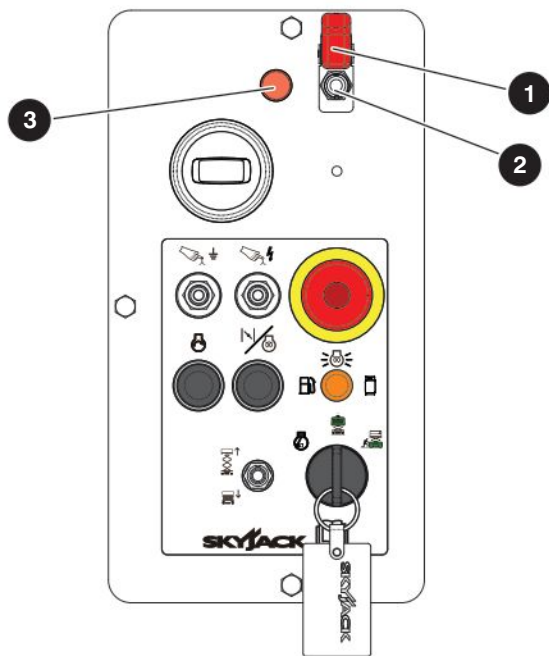

#### 4.3-6 Do a test of the positive air shutoff (optional equipment)

##### **CAUTION**

Do not do this function test while the engine is on.

##### **WARNING**

Burn hazard. Do not touch hot engine components without the correct PPE. Let the engine cool before you do an inspection or servicing. If you do not obey, there is a risk of death or serious injury.

1. Make sure these power connections are ON:
  - The **main power disconnect** switch
  - The **emergency-stop** button on the base control console
  - The **emergency-stop** button on the platform control console
2. Make sure that the engine is off.
3. Open the engine compartment cover.
4. Lift the switch guard **1** for the positive air shutoff on the base control console.
5. Move the **positive air shut-off** switch **2** to the on position to engage the shutoff valve **4**.

6. Move the **positive air shut-off** switch to the off position to disengage the shutoff valve **5**. The **light 3** continuously illuminates.
  - **Result:** The shutoff valve disengages after 20 seconds.
7. Make sure the **positive air shut-off** switch is put back to the off position, and that the switch guard is down. Push the engine compartment cover until the latch locks into position.



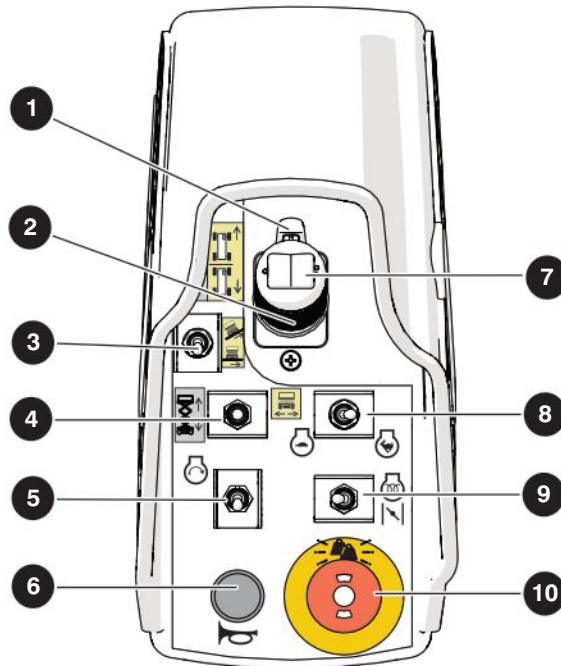

#### 4.3-7 Do a test of the platform emergency-stop

1. Turn the **idle/platform/base key** switch on the base control console to the **platform position**.

#### **⚠ WARNING**

**Fall Hazard. Use the three points of contact principle when you use the MEWP ladder to enter or exit the platform. If you do not obey, there is a risk of death or serious injury.**

2. Use the MEWP ladder to enter the platform.
3. Close the gate.
4. Pull the **emergency-stop** button **10** on the platform control console.
5. Start the engine.
6. Push the **emergency-stop** button **10**.
  - **Result:** The engine stops.

#### 4.3-8 Do a test of the function-enable switch

1. Make sure that the path you plan to travel is clear.
2. Pull the **emergency-stop** button **10**.
3. Start the engine.
4. Move the **lift/off/drive** switch **4** to the **drive position**.
5. Do not use the **function-enable** switch **1**, and try to drive the MEWP by moving the controller handle forward.
  - **Result:** The drive function does not operate.

#### 4.3-9 Do a test of the steer function

1. Move the **lift/off/drive** switch **4** to the **drive position**.
2. Squeeze and hold the **function-enable** switch **1**.
3. Press the **steering rocker** switch **7** on top of the **controller handle** to steer left and right.
  - **Result:** The steer wheels turn left and right.

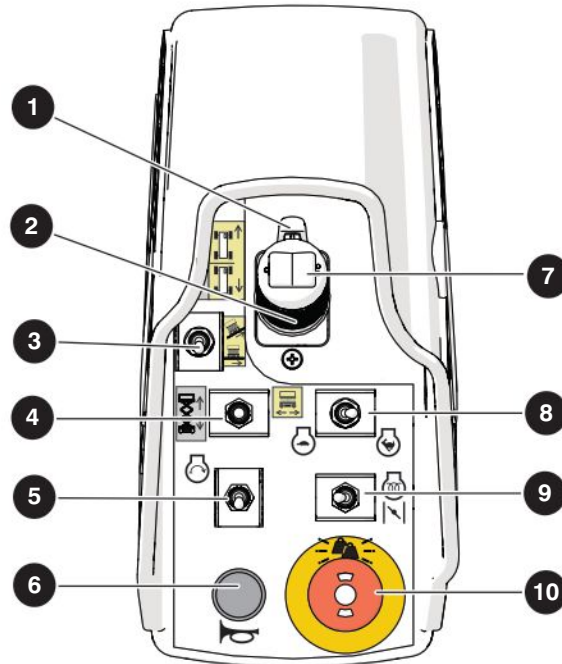

#### 4.3-10 Do a test of the drive function

1. Make sure the path of intended motion is clear.
2. Move the **lift/off/drive** switch **4** to the **drive position**.
3. Squeeze and hold the **function-enable** switch **1**.
4. Slowly push the **controller handle** **2** until the MEWP starts to move. Then, release the handle, so that it goes back to the center position.
  - **Result:** The MEWP moves in the forward direction and then stops.
5. Slowly pull the **controller handle** **2** until the MEWP starts to move. Then, release the handle, so that it goes back to the center position.
  - **Result:** The MEWP moves in the opposite direction and then stops.

#### 4.3-11 Do a test of the anti-tiedown function

1. Make sure the path of intended motion is clear.
2. Move the **lift/off/drive** switch **4** to the **drive position**.
3. Squeeze and hold the **function-enable** switch **1** for 7 seconds.
4. Slowly push the **controller handle** **2** to move the MEWP in the forward direction.
  - **Result:** The MEWP does not move in the forward direction.

#### 4.3-12 Do a test of the brakes

##### **IMPORTANT**

The brakes engage instantly when you release the **function-enable** switch. This causes the MEWP to stop immediately.

1. Make sure the path of intended motion is clear.
2. Move the **lift/off/drive** switch **4** to the drive position.
3. Squeeze and hold the **function-enable** switch **1**.
4. Drive the MEWP forward and then rearward. Release the **controller handle** **2**.
  - **Result:** The MEWP stops. Do not operate the MEWP if the MEWP pulls to one side while it stops. A service technician must do a check on the brake adjustments.
5. Drive the MEWP forward and then rearward. Release the **function-enable** switch **1** only.
  - **Result:** The MEWP comes to an instant and sudden stop. Do not operate the MEWP if it does not stop immediately, or it pulls to one side while it stops. A service technician must do a check on the brake adjustments.

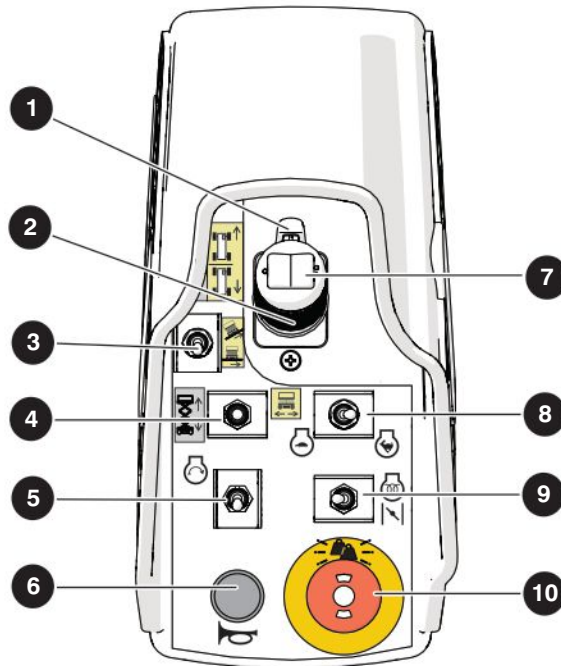

#### 4.3-13 Do a test of the platform raise and lower functions

##### **WARNING**

Look for overhead obstructions or other possible hazards around the MEWP when you raise the platform. Do not lower the platform unless the area below is clear of personnel and obstructions. If you do not obey, there is a risk of death or serious injury.

1. Move the **lift/off/drive** switch **4** to the **lift position**.
2. Squeeze and hold the **function-enable** switch **1**.
3. Push the **controller handle** **2** to raise the platform by approximately 0.5 m (20 in).
  - **Result:** The platform raises.
4. Squeeze and hold the **function-enable** switch **1**.
5. Pull the **controller handle** **2** to fully lower the platform.
  - **Result:** The platform fully lowers.

#### 4.3-14 Do a test of the horn

1. Press the horn button **6**.
  - **Result:** The horn makes a sound.

#### 4.3-15 Do a test of the elevated travel speed

##### **WARNING**

Look for overhead obstructions or other possible hazards around the MEWP when you raise the platform. Do not lower the platform unless the area below is clear of personnel and obstructions. If you do not obey, there is a risk of death or serious injury.

1. Make sure the path of intended motion is clear.
2. Raise the platform until it is at a height of approximately 4.3 m (14 ft).
3. Drive the MEWP forward and then rearward.
  - **Result:** The MEWP drives slower than when it was in the lowered travel position.



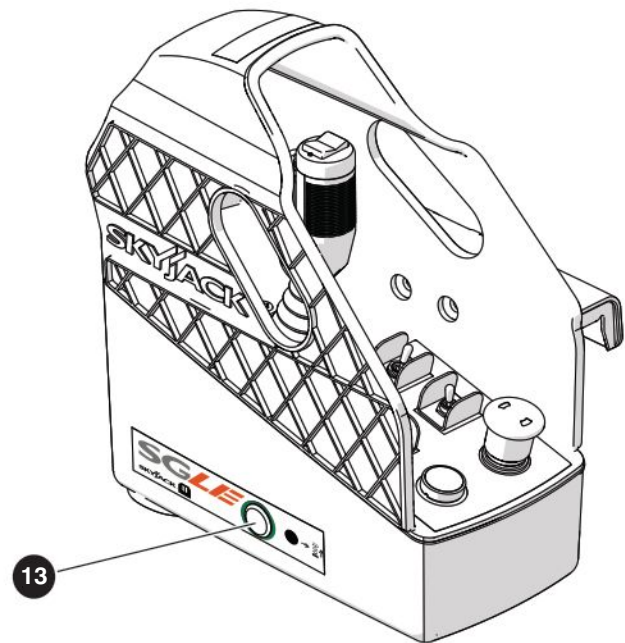
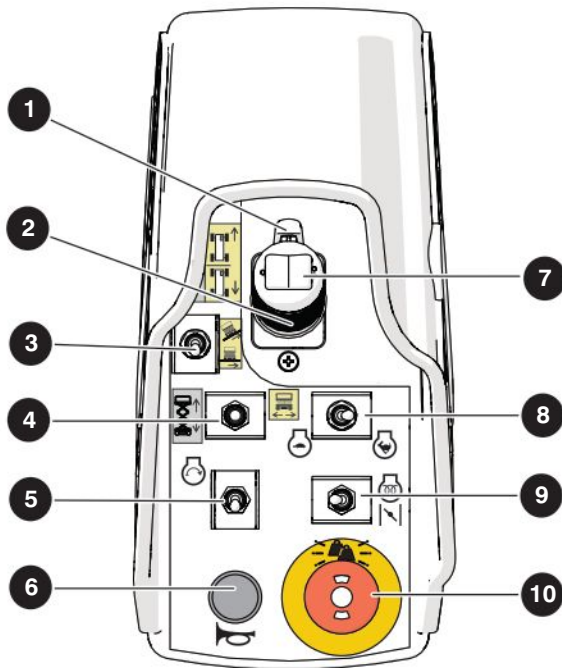

#### 4.3-16 Do a test of the SGLE switch (optional equipment)

##### **WARNING**

Look for overhead obstructions or other possible hazards around the MEWP when you raise the platform. Do not lower the platform unless the area below is clear of personnel and obstructions. If you do not obey, there is a risk of death or serious injury.

1. Start the engine.
2. Move the **lift/off/drive** switch **4** to the lift position.
3. Do not squeeze the **function-enable** switch **1** or push the **SGLE** button **13**. Push and pull the **controller handle** **2** to raise and lower the platform.
  - **Result:** The platform does not raise or lower.
4. Push and hold the **SGLE** button **13** only. Do not squeeze the **function-enable** switch **1**. Push and pull the **controller handle** **2** to raise or lower the platform.
  - **Result:** The platform does not raise or lower.

5. Push and hold the **SGLE** button **13**. Squeeze the **function-enable** switch **1**. Push and pull the **controller handle** **2** to raise or lower the platform.
  - **Result:** The platform raises and lowers.
6. Squeeze the **function-enable** switch **1** only. Do not push the **SGLE** button **13**. Push and pull the **controller handle** **2** to raise or lower the platform.
  - **Result:** The platform lowers, but does not raise.

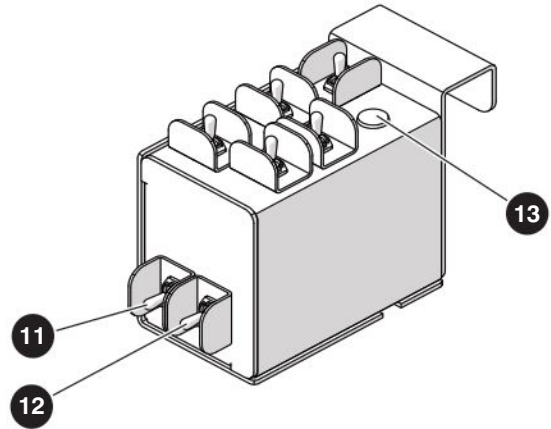
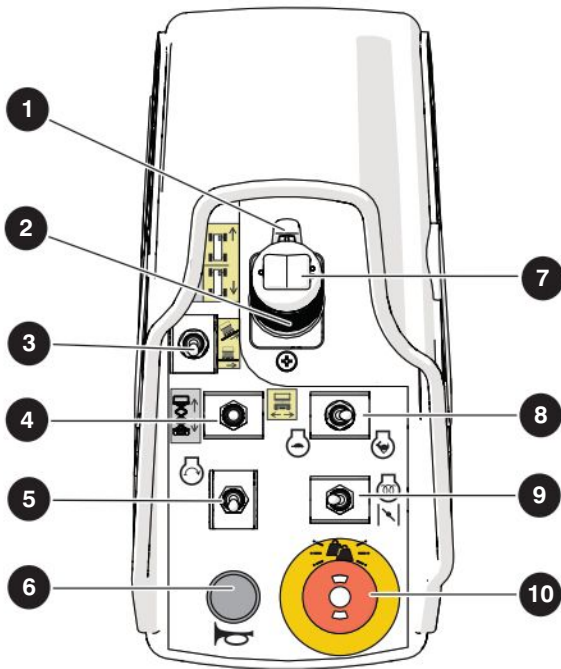

#### 4.3-17 Do a test of the outrigger interlocks (optional equipment)

1. Use the MEWP ladder to enter the platform.
2. Start the engine.
3. Move the **lift/off/drive** switch 4 to the lift position.
4. Move and hold the **auto-level enable** switch 12 in the enable position.
5. Move and hold the **auto level** switch 11 in the extend position to extend all four outriggers 10 cm (4 in).
6. Squeeze the **function-enable** switch 1 and push the **controller handle** 2 to raise the platform
  - **Result:** The platform does not raise.
7. Move and hold the **auto-level enable** switch 12 in the enable position.
8. Move and hold the **auto level** switch 11 in the retract position to fully retract all four outriggers.
  - **Result:** All four outriggers fully retract.
9. Move and hold the **auto-level enable** switch 12 in the enable position.
10. Move and hold the **auto level** switch 11 in the extend position to extend all four outriggers 10 cm (4 in). When the first outrigger hits the ground (observed as the initial movement), stop lowering the outriggers, and observe all four outriggers.
  - **Result:** All four legs have moved more than 5 cm (2 in) and all the pads are near the ground.
11. Resume the deployment of the outriggers until the platform has leveled itself.
  - **Result:** All four outriggers extend until they hold the MEWP weight and put the MEWP in a level position. The outriggers stop automatically when the platform is level. The outrigger light 13 goes on.

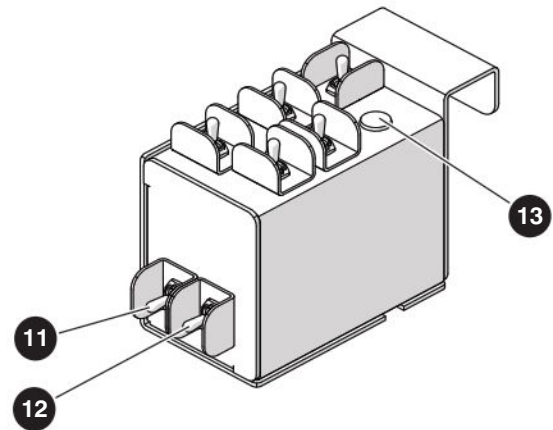
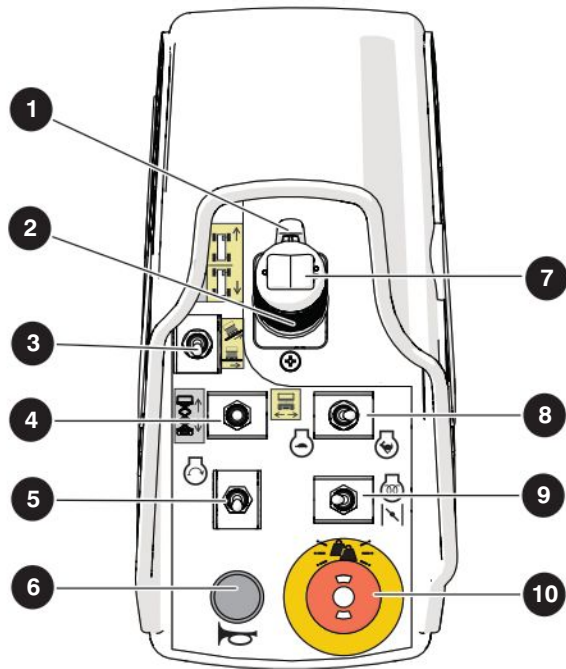

### 4.3-18 Do a test of the auto-level (optional equipment)

Refer to [section 5.10](#) for the auto-level operation.

#### NOTE

Make sure that you:

- Park the MEWP on a firm, level surface. Remove all obstructions.
- Fully lower the platform.
- Fully retract the outriggers.

#### **WARNING**

**If the outrigger interlocks fail to operate correctly, lock and tag the MEWP. Remove the MEWP for servicing. Only a qualified service technician must repair the MEWP. If you do not obey, there is a risk of death or serious injury.**

1. Use the MEWP ladder to enter the platform.
2. Start the engine.
3. Move the **lift/off/drive** switch **4** to the lift position.
4. Move and hold the **auto-level enable** switch **12** in the enable position.

5. Move and hold the **auto level** switch **11** in the extend position to extend the outriggers until all four outriggers are on the ground and the platform is level.

#### **WARNING**

**Look for overhead obstructions or other possible hazards around the MEWP when you raise the platform. Do not lower the platform unless the area below is clear of personnel and obstructions. If you do not obey, there is a risk of death or serious injury.**

6. Raise the platform by approximately 0.3 m (1 ft).
  - **Result:** The platform raises.
7. Fully lower the platform.
  - **Result:** The platform fully lowers.
8. Move and hold the **auto-level enable** switch **12** in the enable position.
9. Move and hold the **auto level** switch **11** in the retract position to fully retract all four outriggers.
  - **Result:** All four outriggers fully retract.

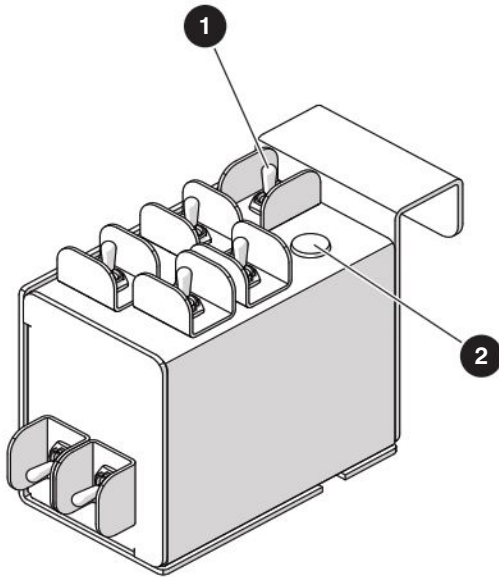

#### 4.3-19 Do a test of the generator (optional equipment)

1. Use the MEWP ladder to enter the platform.
2. Start the engine.
3. Move the **generator** switch ① to the on position.
  - **Result:** The engine speed automatically changes to high throttle. The generator starts. The light ② goes on.
4. Move the **generator** switch ① to the off position.
  - **Result:** The generator stops. The light ② goes off. The throttle goes back to idle.

### 4.4 Operator's Checklist (page 1 of 2)



## SJ6826 RT, SJ6832 RT Daily Operator's Checklist

Serial Number: \_\_\_\_\_  
 Model: \_\_\_\_\_  
 Hourmeter Reading: \_\_\_\_\_  
 Date: \_\_\_\_\_  
 Time: \_\_\_\_\_

Operator's Name  
 (Printed): \_\_\_\_\_  
 Operator's Signature: \_\_\_\_\_

Each item shall be inspected using the appropriate section of the Skyjack operating manual. As each item is inspected, check or complete the appropriate box.

**P** PASS      **N/A** NOT APPLICABLE

**Add a comment if the item does not pass inspection.**

	P	N/A	Comment (if item does not pass inspection)
<b>Visual and Daily Maintenance Inspections</b>			
<b>Labels - Do an inspection for damaged, or missing labels</b>			
<b>Electrical - Do an inspection for loose, damaged, or missing components</b>			
<b>Hydraulic - Do an inspection for loose, damaged, or missing components</b>			
<b>Base - Do an inspection for loose, damaged, or missing components</b>			
Base weldment			
Steer cylinder			
Tie rod			
Emergency-lowering access rod			
Ladder			
Outriggers (optional equipment)			
<b>Wheels/tires - Do an inspection for loose, damaged, or missing components</b>			
Wheel/tire assembly			
Whee nuts			
<b>Engine compartment - Do an inspection for loose, damaged, or missing components</b>			
Main power disconnect switch			
Base control			
Engine compartment cover			
Battery			
Hydraulic pump			
Radiator			
Engine coolant			
Muffler and exhaust			
Engine and pivot tray			
Engine oil level			
Engine intake air filter			
Belts			
Propane tank (optional equipment)			
<b>Hydraulic compartment - Do an inspection for leaks and loose, damaged, or missing components</b>			
Hydraulic compartment cover			
Hydraulic tank			
Hydraulic oil level			
Hydraulic return filter			
Fuel tank			
Main manifold			
Gear-type flow divider			

**NOTE:** Make a copy of this page or go to [www.skyjack.com](http://www.skyjack.com) for a copy that you can print.

# Operator's Checklist (page 2 of 2)

check or complete the appropriate box.

Add a comment if the item does not pass inspection.

	P	N/A	Comment (if item does not pass inspection)
<b>Platform assembly - Do an inspection for loose, damaged, or missing components</b>			
Platform railings			
Fall-protection anchorages			
AC power socket			
Platform control console			
Manual storage box			
<b>Lift mechanism - Do an inspection for loose, damaged, or missing components</b>			
Sliders and rollers			
Maintenance support			
Scissor assembly			
Scissor bumpers			
Lift cylinders			
Angle transducer			
<b>Optional equipment and attachments - Do an inspection for leaks and loose, damaged, or missing components.</b>			
<b>Function Tests</b>			
Do a test of the main power disconnect switch			
Do a test of the emergency-stop button on the base			
Do a test of the load-sensing module self-check			
Do a test of the idle/platform/base key switch			
Do a test of the emergency-lowering function			
Do a test of the positive air shutoff (optional equipment)			
Do a test of the platform emergency-stop			
Do a test of the function-enable switch			
Do a test of the steer function			
Do a test of the drive function			
Do a test of the anti-tiedown function			
Do a test of the brakes			
Do a test of the platform raise and lower functions			
Do a test of the horn			
Do a test of the elevated travel speed			
Do a test of the SGLE switch (optional equipment)			
Do a test of the outrigger interlocks (optional equipment)			
Do a test of the auto-level (optional equipment)			
Do a test of the generator (optional equipment)			

1905AA

**NOTE:** Make a copy of this page or go to [www.skyjack.com](http://www.skyjack.com) for a copy that you can print.

# Section 5 – Operation

## **⚠ WARNING**

Do not operate this MEWP without authorization and training. If you do not obey, there is a risk of death or serious injury.

Do these tasks in sequence before MEWP operation:

1. Visual and daily maintenance inspections. Refer to [section 4.2](#).
2. Function tests. Refer to [section 4.3](#).
3. Worksite inspection. Refer to [section 2.4](#).
4. If a risk assessment finds that a rescue plan is necessary, make sure you have a system of communication. The communication must be between the personnel on the platform and the selected support personnel. The selected support personnel must know how to use the base controls to lower the platform.

## **⚠ WARNING**

Do not operate the MEWP if:

- It does not operate correctly
- It is damaged or shows worn or missing parts
- The safety devices are tampered with or disabled
- It is locked and tagged for servicing or repair
- It was modified without permission from Skyjack and the MEWP owner.

If you do not obey, there is a risk of death or serious injury.

## **⚠ WARNING**

Fall Hazard. Use the three points of contact principle when you use the MEWP ladder to enter or exit the platform. If you do not obey, there is a risk of death or serious injury.

## 5.1 Energize the base control console

1. Turn the **main power disconnect** switch to the on position.
2. Use the MEWP ladder to enter the platform.
3. Close the gate.
4. Pull the **emergency-stop** button on the platform control console.
5. Use the MEWP ladder to exit the platform.
6. Pull the **emergency-stop** button on the base control console.

## **⚠ WARNING**

If you do not hear a beep, and the light does not come on, lock and tag the MEWP. Remove the MEWP for servicing. If you do not obey, there is a risk of death or serious injury.

7. Move the **idle/platform/base key** switch to the base position.
8. Start the engine. Do the steps that follow for your engine fuel type and temperature.

Engine type	Cold engine	Warm engine
Diesel	<ol style="list-style-type: none"> <li>a. Push and hold the <b>glow plug</b> button for 15 to 20 seconds, until the light turns off.</li> <li>b. Push the <b>engine start</b> button.</li> </ol>	<ol style="list-style-type: none"> <li>a. Push the <b>engine start</b> button.</li> </ol>
Dual fuel	<ol style="list-style-type: none"> <li>a. Move the <b>fuel</b> switch to the liquid propane gas or gasoline position.</li> <li>b. Push and hold the <b>choke</b> button.</li> <li>c. Push the <b>engine start</b> button.</li> </ol>	<ol style="list-style-type: none"> <li>a. Push the <b>engine start</b> button.</li> </ol>



## 5.2 Raise or lower the platform with the base control console

1. Energize the base control console (refer to [section 5.1](#)).
2. Turn and hold the **idle/platform/base key** switch to the base position.

### WARNING

Look for overhead obstructions or other possible hazards around the MEWP when you raise the platform. Do not lower the platform unless the area below is clear of personnel and obstructions. If you do not obey, there is a risk of death or serious injury.

3. Move the **lower/neutral/raise** switch to the raise or lower position and hold it to raise or lower the platform. Release the switch to stop.

## 5.3 Energize the platform control console

1. Turn the **main power disconnect** switch to the on position.

### WARNING

If you do not hear a beep, and the light does not come on, lock and tag the MEWP. Remove the MEWP for servicing. If you do not obey, there is a risk of death or serious injury.

2. Pull the **emergency-stop** button on the base control console.
3. Turn the **idle/platform/base key** switch to the platform position.

### WARNING

**Fall Hazard.** Use the three points of contact principle when you use the MEWP ladder to enter or exit the platform. If you do not obey, there is a risk of death or serious injury.

4. Use the MEWP ladder to enter the platform.
5. Close the gate.
6. Pull the **emergency-stop** button on the platform control console.
7. Start the engine.

## 5.4 Raise or lower the platform with the platform control console

### WARNING

Look for overhead obstructions or other possible hazards around the MEWP when you raise the platform. Do not lower the platform unless the area below is clear of personnel and obstructions. If you do not obey, there is a risk of death or serious injury.

1. Move the **lift/off/drive** switch to the lift position.
2. Squeeze and hold the **function-enable** switch.
3. Move the **controller handle** forward or rearward to go to the necessary height.

### NOTE

*The lower function is not proportional.*

4. Move the **controller handle** to the neutral central position to stop. Release the **function-enable** switch.

### WARNING

Push the emergency-stop button when you are at the necessary location or elevation. This prevents unintended MEWP movement. If you do not obey, there is a risk of death or serious injury.

### WARNING

If the tilt alarm makes a sound, and the platform does not raise or does not fully raise:

1. Fully lower the platform immediately.
2. Make sure the MEWP is on a firm, level surface.

## 5.5 Raise and lower with the SGLE platform control console (optional equipment)

1. Energize the platform control console.
2. Move the **lift/off/drive** switch to the lift position.

### WARNING

Look for overhead obstructions or other possible hazards around the MEWP when you raise the platform. Do not lower the platform unless the area below is clear of personnel and obstructions. If you do not obey, there is a risk of death or serious injury.

3. Push and hold the **SGLE** push-button and squeeze the **function-enable** switch.
4. Push the **controller handle** until you are at the necessary height.
5. Squeeze the **function-enable** switch.
6. Pull the **controller handle** to lower the platform.

### NOTE

The SGLE does not have an effect on these functions: lower, drive, steer, auto-level, or emergency-lowering.

7. Release the **controller handle** until it goes back to the center position to stop. Release the **function-enable** switch.

## 5.6 Drive forward or rearward

### WARNING

Make sure there are no personnel or obstructions in the path of travel. Acquaint yourself with the blind spots of the MEWP. If you do not obey, there is a risk of death or severe injury.

1. Energize the platform control console (refer to [section 5.3](#)).
2. Move the **lift/off/drive** switch to the drive position.
3. Squeeze and hold the **function-enable** switch.
4. Move the **controller handle** forward or rearward to drive at and in the necessary speed and direction.

5. Move the **controller handle** to the neutral central position to stop. Release the **function-enable** switch.

### WARNING

Push the emergency-stop button when you are at the necessary location or elevation. This prevents unintended MEWP movement. If you do not obey, there is a risk of death or serious injury.

## 5.7 Steer

1. Energize the platform control console (refer to [section 5.3](#)).
2. Move the **lift/off/drive** switch to the drive position.
3. Squeeze and hold the **function-enable** switch.
4. Push the **steering rocker** switch on top of the **controller handle** in one of the two directions to steer.

### NOTE

The steer function is not proportional. Drive and steer functions can be active at the same time.

### WARNING

Push the emergency-stop button when you are at the necessary location or elevation. This prevents unintended MEWP movement. If you do not obey, there is a risk of death or serious injury.

## 5.8 Select the level-drive or inclined-drive mode

- Select the level-drive mode when you drive on a level surface.
  1. To use the level drive mode, move the **inclined-drive/level-drive** switch to the level-drive (high speed/low torque) position.

### WARNING

**Do not drive the MEWP in the elevated position on a slope. Fully retract the MEWP before you operate it on a slope. If you do not obey, there is a risk of death or severe injury.**

- Select the inclined-drive mode in these situations:
  - When you drive up or down slopes
  - When you drive on rough ground
  - When you drive the MEWP on to or remove it from a transport vehicle.
- 1. To use the inclined-drive, move the **inclined-drive/level-drive** switch to the inclined-drive (low speed/high torque) position.

## 5.9 Extend/retract the extension platform

### WARNING

**Push the emergency-stop button when you are at the necessary location or elevation. This prevents unintended MEWP movement. If you do not obey, there is a risk of death or serious injury.**

1. Disengage the **lock-pin** ①.
2. Deploy the **extension handles** ②.
3. Push or pull the **extension handles** to extend or retract the extension platform.
4. Retract the **extension handles** to lock the extension platform in position.

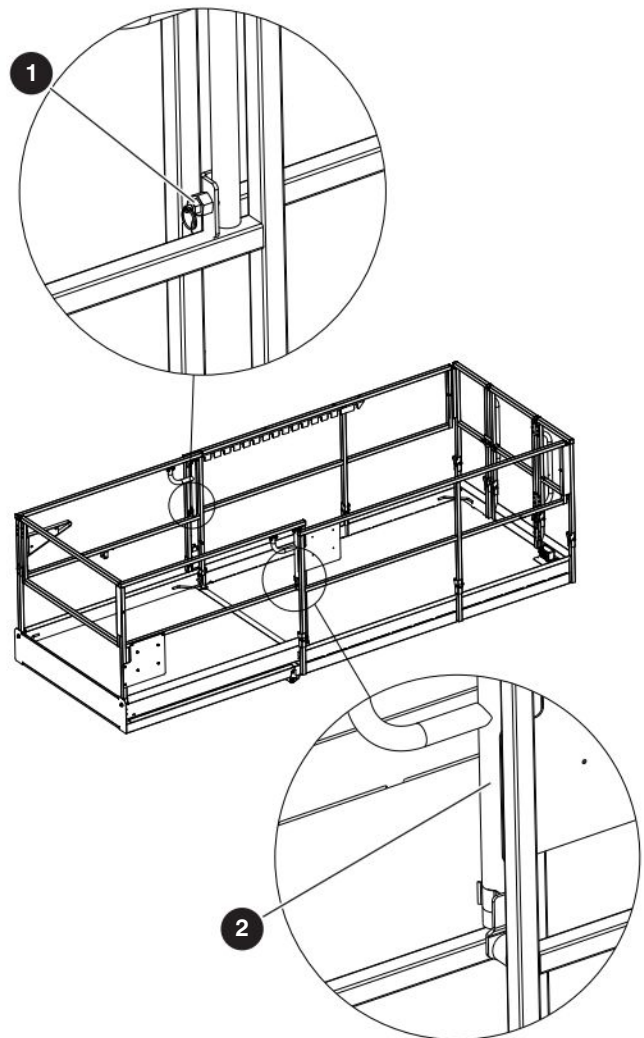

## 5.10 Use the auto-level (optional equipment)

### WARNING

Look for overhead obstructions or other possible hazards around the MEWP when you raise the platform. Do not lower the platform unless the area below is clear of personnel and obstructions. If you do not obey, there is a risk of death or serious injury.

### WARNING

Tip-over hazard. Make sure the surface below the tires and outrigger pads is firm and can hold the MEWP and the rated load. Do not put the outrigger pads on street drains, manhole covers, or other unsupported surfaces. If you do not obey, there is a risk of death or serious injury.

#### Level the MEWP

1. Fully lower the platform. Refer to [section 5.2](#) and [section 5.4](#).
2. Move and hold the **auto-level enable** switch in the **enable** position.
3. Move and hold the **auto-level** switch in the **extend** position to extend all four outriggers. The level indicator light shows the auto-level outrigger condition.

Auto-level light	Outrigger condition
Off	The outriggers are fully retracted. The outriggers are not active.
Flashing slowly	Indicates the outrigger extension or retraction.
Flashing quickly	The outriggers are extended and the MEWP is not level, or there is an outrigger or auto-level function error.
On	The outriggers are extended and the MEWP is level. The light is on while the auto-level function is active only.

4. Make sure each outrigger pad is in firm contact over its entire surface area, with a suitable supporting surface.

### NOTE

The drive functions are disabled if the outriggers are not fully retracted.

### CAUTION

If the outrigger alarm makes a sound during operation, immediately lower the platform and put the MEWP on a firm surface. The MEWP must be on a firm surface for you to operate it.

#### Retract the outriggers

1. Fully lower the platform.
2. Move and hold the **auto-level enable** switch in the **enable** position.
3. Move and hold the **auto-level** switch in the **retract** position to retract all four outriggers.

### IMPORTANT

Limit switches prevent outrigger damage. If the drive functions are not available, do a visual inspection of the outriggers to make sure they are all fully retracted.

## 5.11 Start and stop the generator (optional equipment)

1. Start the engine.
2. Move the **lift/off/drive** switch to the lift position.
3. Move the **generator** switch to the on position to start the generator.
4. Move the **generator** switch to the off position to stop the generator.

### NOTE

The generator stops in these situations:

- You start the drive, lift, or auto-level functions
- You push the emergency-stop button
- You change the idle/platform/base key switch position
- The engine stalls.

The generator stays on while you lower the platform.

## 5.12 MEWP shutdown

### **WARNING**

Look for overhead obstructions or other possible hazards around the MEWP when you raise the platform. Do not lower the platform unless the area below is clear of personnel and obstructions. If you do not obey, there is a risk of death or serious injury.

1. Select a reasonably well-protected location to park the MEWP. This location must have a firm, level surface, clear of obstructions, and traffic.
2. Fully lower the platform.
3. Push the **emergency-stop** button.

### **WARNING**

**Fall Hazard. Use the three points of contact principle when you use the MEWP ladder to enter or exit the platform. If you do not obey, there is a risk of death or serious injury.**

4. Use the MEWP ladder to exit the platform.
5. Turn the **idle/platform/base key** switch to the idle position on the base control console and remove the key.
6. Push the **emergency-stop** button.
7. Turn the **main power disconnect** switch to the off position.

# Section 6 – Additional Procedures

## 6.1 Use the emergency-lowering function

With the emergency-lowering system, you can lower the platform if there is a failure of the primary power.

### **WARNING**

**Crush hazard. Keep clear of the lift mechanism when you use the emergency-lowering function. If you do not obey, there is a risk of death or serious injury.**

1. Remove obstructions before you lower the platform.
2. If necessary, retract the extension platform or move the MEWP to clear an obstruction.

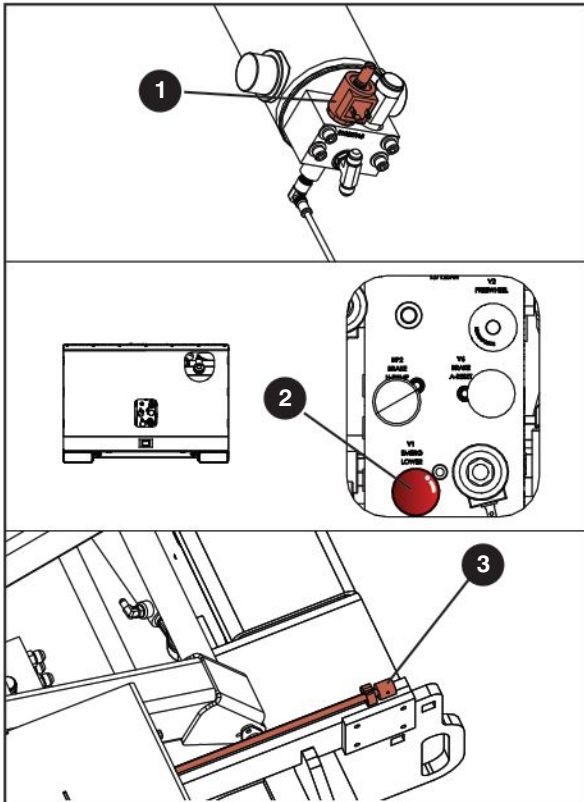

3. Turn the **main power disconnect** to the off position.
4. Find the override knob of the holding valve **1** at the bottom of each lift cylinder.
5. Press and turn the knob of each holding valve counterclockwise until it stops. If it is necessary, use the emergency-lowering access rod **3** on the base of the MEWP.

### **WARNING**

**Look for overhead obstructions or other possible hazards around the MEWP when you raise the platform. Do not lower the platform unless the area below is clear of personnel and obstructions. If you do not obey, there is a risk of death or serious injury.**

6. Find the emergency-lowering valve **2** on the hydraulic compartment, pull and hold the emergency-lowering valve to lower the platform.
7. Press and turn the override knobs of each holding valve clockwise until it stops to restore normal operation.



## 6.2 Release the brakes manually

### **⚠ WARNING**

Do not manually disengage the brakes if the MEWP is on a slope. If you do not obey, there is a risk of death or serious injury.

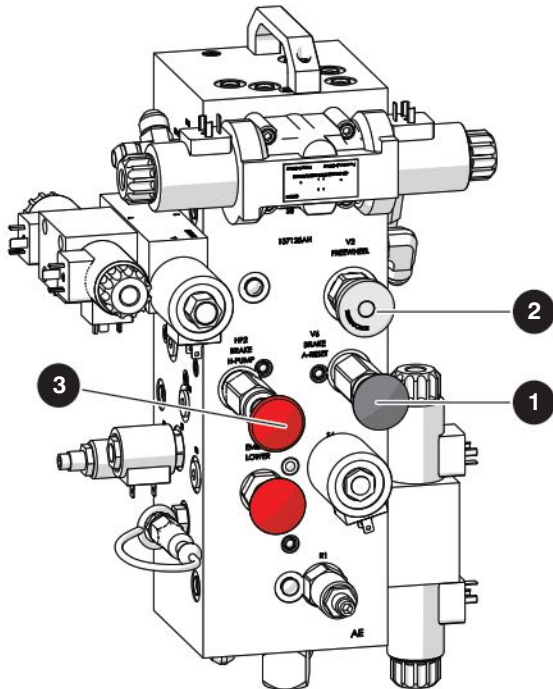

1. Make sure that the MEWP is on firm, level ground. Use wheel chocks or blocks at the front and rear of the wheels to prevent MEWP movement.
2. Turn the **main power disconnect** switch to the off position.
3. Turn the freewheeling valve **2** counterclockwise to the fully open position.
4. Push the plunger of the brake auto-reset valve **1** on the main manifold in the hydraulic compartment.
5. Continuously push and release the **knob 3** of the hand pump until you feel firm resistance. The brake is released.

## 6.3 Winch and tow the MEWP

### **⚠ WARNING**

Tip-over hazard. Make sure that platform is fully lowered before you push, winch or tow. Sudden movement can cause the MEWP to become unstable. If you do not obey, there is a risk of death or serious injury.

### **⚠ WARNING**

Tip-over hazard. In emergency situations, where the MEWP functions are unavailable, and an obstruction prevents the platform lower function, carefully move the MEWP. Move the MEWP sufficiently far away to clear the obstruction. Do not move at a speed faster than 50 mm/sec (2 in/sec). If you do not obey, there is a risk of death, serious injury, and/or MEWP damage.

### **⚠ WARNING**

When you push, winch or tow, do not move the MEWP at a speed faster than 3.2 km/h (2.0 mph). If you do not obey, there is a risk of death or serious injury.

### **⚠ WARNING**

Do not push, winch, or tow the MEWP onto a slope. Only brake the tow vehicle slowly. Do not pull the MEWP down a slope to a winch. Make sure that there are no personnel in the path you plan to travel. If you do not obey, there is a risk of death, serious injury, and/or MEWP damage.

### **⚠ WARNING**

Do not manually disengage the brakes if the MEWP is on a slope. If you do not obey, there is a risk of death or serious injury.

### **⚠ WARNING**

Tip-over hazard. Disengage the brakes manually before you push, winch, or tow the MEWP. If you do not obey, there is a risk of death or serious injury.



1. Release the brakes manually. Refer to [section 6.2](#).
2. Remove the wheel chocks or blocks.
3. Push, winch, or tow the MEWP to the necessary location.
4. Put the MEWP on a firm, level surface.
5. Use wheel chocks or blocks at the front and rear of the wheels to prevent MEWP movement.
6. Pull out the **plunger** of the brake auto-reset valve to re-engage the brakes.
7. Turn the freewheeling valve clockwise until it is closed tightly.

### **WARNING**

**Engage the brakes immediately after the MEWP is at the necessary location. If you do not obey, there is a risk of death or serious injury.**

## 6.4 Move the MEWP for transport

When you drive a MEWP onto or remove it from a transport vehicle, on a public road, give protection to the person(s) involved. Protection can include:

- Warning cones
- Road signs and signaling devices
- Applicable personal protective equipment, such as reflective clothing
- Flag personnel to warn other vehicles of the MEWP and other related vehicles
- Other applicable control measures.

Obey all the national, state/provincial/territorial, and local safety rules when you move the MEWP for transport. Only qualified personnel with authorization must drive the MEWP on to or remove it from a transport vehicle.

Be sure the vehicle capacity and load equipment, hoists, chains, straps, and other related items are sufficient to withstand the maximum MEWP weight.

Park the transport vehicle on a level surface. Use wheel chocks or blocks to prevent unintended vehicle movement during this operation.

### 6.4-1 Lift the MEWP with a forklift

When you lift the MEWP, you must:

- Turn the **main power disconnect** switch to the off position.
- Close and tightly latch the engine compartment door.
- Retract the extension platform. Correctly insert the lock-pin(s).
- Attach the platform control console to the mounting bracket, or remove the **platform control console**
- Remove all personnel, tools, and materials from the platform.
- Lift the MEWP with the forklift forks in the forklift lift locations **1**. Refer to [Figure 03](#).

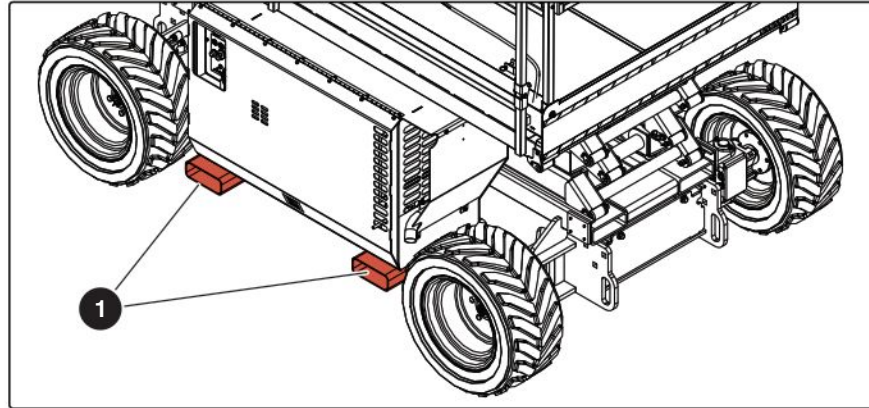

Figure 03 Forklift lift locations

## 6.4-2 Hoist the MEWP

### **WARNING**

Only qualified riggers must operate the machinery during a lift.

When you hoist the MEWP, you must:

- Turn the **main power disconnect** switch to the off position.
- Close and tightly latch the engine compartment door.
- Retract the extension platform. Correctly insert the lock-pin(s).
- Attach the platform control console to the mounting bracket, or remove the **platform control console**
- Remove all personnel, tools, and materials from the platform.
- Attach the rigging to all **four lift points 1**. Refer to [Figure 05](#).

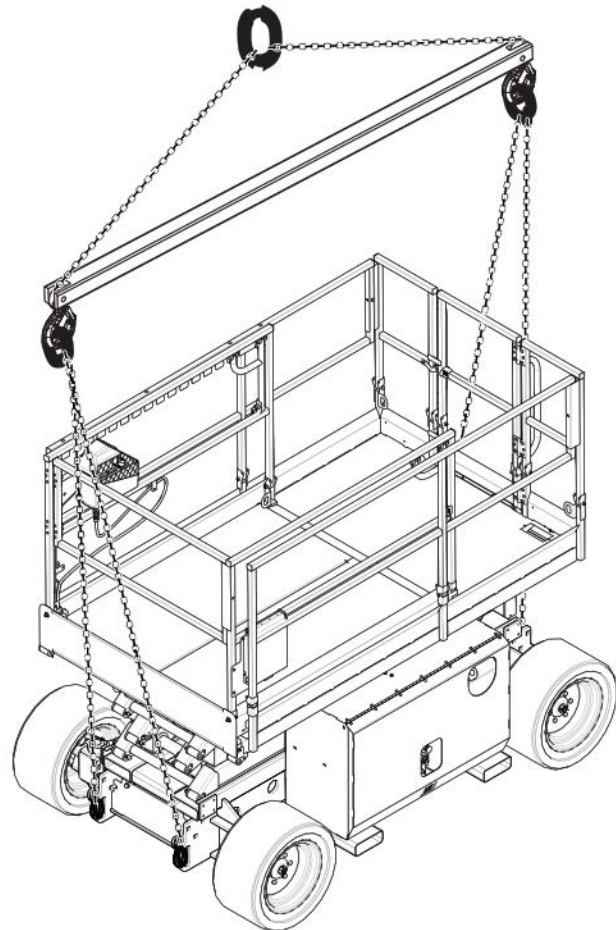

Figure 04 Appropriate method to hoist

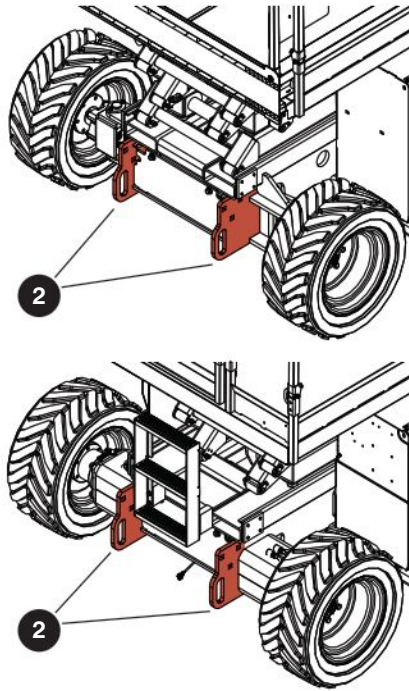

Figure 05 Tie-downs/lift points

## NOTE

For the weight of the MEWP, refer to [section 7.3](#). Horizontally, the **center of gravity** ③ is approximately in the middle of the MEWP, front to back and side to side. Refer to [Figure 06](#). Vertically, the center of gravity is approximately a small distance above the chassis.

## 6.4-3 Drive and tie-down the MEWP

Before you drive the MEWP:

- The ramp or dock capacity must be able to hold the maximum MEWP weight.
- Use side guards (if available) to prevent a fall from the ramp.
- The incline of the ramp must not exceed the MEWP gradeability. Refer to [section 7.3](#).
- Do a test of the MEWP brakes to make sure they operate correctly.
- Move the **inclined-drive/level-drive** switch to the inclined-drive (low speed/high torque) position.

## ⚠ WARNING

When you transport the MEWP, it must be attached to a truck or trailer deck. Use the available tie-down points ② to attach the MEWP. Refer to [Figure 05](#). If you do not obey, there is a risk of death or serious injury.

- Tie-down the MEWP to the transport vehicle using the **tie-down points** ②. Refer to [Figure 05](#).

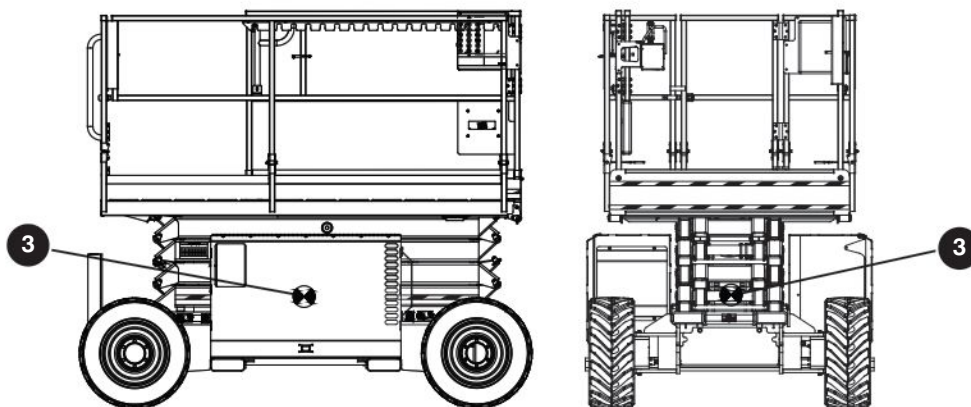

Figure 06 MEWP Center of Gravity

## 6.5 Use the platform control console from the ground

### **⚠ WARNING**

The correct operator location is with the platform control console attached to the right-front side of the platform. Only operate the MEWP from the ground in these conditions:

- To do maintenance
- When you cannot do work safely from the position of the operator on the platform because of an obstruction
- To fold the guardrails.

If you do not obey, there is a risk of death or serious injury.

### 6.5-1 Disconnect and remove the platform control console

1. Disconnect the **platform control console cable** from the **electrical plug** under the platform.

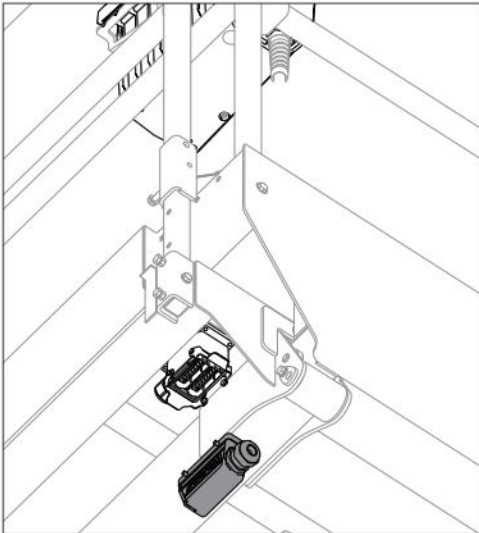

### **⚠ WARNING**

Fall Hazard. Use the three points of contact principle when you use the MEWP ladder to enter or exit the platform. If you do not obey, there is a risk of death or serious injury.

2. Use the MEWP ladder to enter the platform.

3. Remove the **control console mounting bracket lock-pin 1** from the mounting bracket. Remove the **platform control console** from the mounting bracket.
4. Remove the **control cable lock-pin** from the railing clamp. Remove the **control cable** from the clamp.

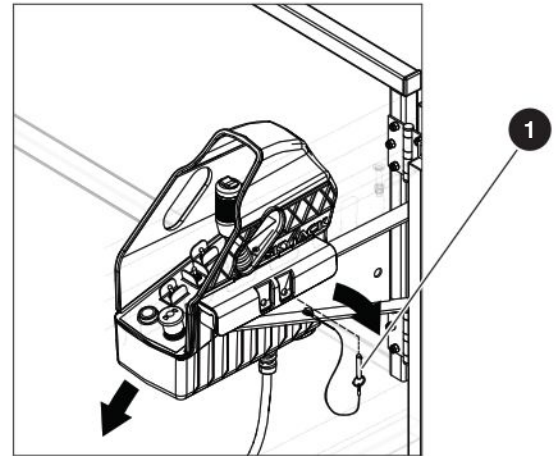

5. Use the MEWP ladder to exit the platform.

### 6.5-2 Operate the MEWP from the ground

### **⚠ WARNING**

Make sure the operator and the control console point in the same direction as the front of the MEWP.

Do not drive the MEWP toward yourself.

Keep away from crush hazards. Stay clear of the MEWP and out of the direction of travel.

When you use a ramp to drive the MEWP on to or remove it from a transport vehicle, make sure all personnel, which includes the operator:

- Stay away from the direction of a possible tip-over of the MEWP.
- Stay out of the path of movement of the MEWP down the ramp.

If you do not obey these instructions, there is a risk of death or serious injury.



**⚠ CAUTION**

Make sure the control console cable does not become entangled with the MEWP or objects that surround the MEWP. If you do not obey, there is a risk of MEWP damage.

1. Before you operate the MEWP, do a full worksite inspection to identify possible hazards in your work area. Refer to [section 2.4](#).
2. Cordon-off the pathway you plan to travel.

**⚠ WARNING**

Crush hazard. Make sure that there are no personnel in the path you will travel. Tell personnel around the path before you move the MEWP. Use a second person to monitor the movement of the MEWP. Make sure that person stays at a safe distance. If you do not obey, there is a risk of death or serious injury.

3. Stay behind or to the side of the MEWP.
4. Connect the **platform control console cable** to the **electrical connector** in the engine compartment of the MEWP.

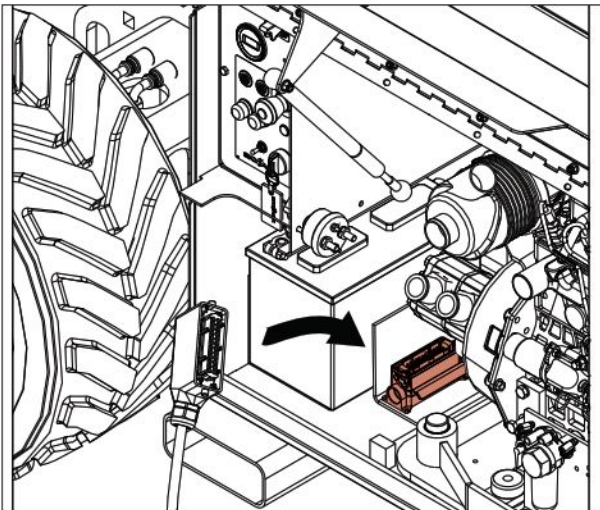

5. Move the **inclined-drive/level-drive** switch to the inclined-drive position.
6. Use as low a speed as practical to drive the MEWP forward to the necessary location.
7. Push the **emergency-stop** button when the MEWP is at the necessary location.
8. Turn the **main power disconnect** switch to the off position.

**⚠ WARNING**

Fall Hazard. Use the three points of contact principle when you use the MEWP ladder to enter or exit the platform. If you do not obey, there is a risk of death or serious injury.

9. Use the MEWP ladder to enter the platform.

**⚠ CAUTION**

Make sure each lock-pin is correctly installed with the detent ball of each lock-pin fully through the hole.

10. Install the **platform control console** onto the mounting bracket. Install the **lock-pin** in the mounting bracket.
11. Install the **control cable** into the railing clamp and install the **lock-pin**.

**⚠ WARNING**

Fall Hazard. Use the three points of contact principle when you use the MEWP ladder to enter or exit the platform. If you do not obey, there is a risk of death or serious injury.

12. Use the MEWP ladder to exit the platform.
13. Connect the **platform control console cable** to the **electrical connector** below the platform.

## 6.6 Fold the guardrails

When folded down, the guardrail system decreases the total height of the retracted MEWP for transport.

### **WARNING**

Fall hazard. To prevent a fall, keep away from the sides of the platform when you fold or unfold the guardrails. If you do not obey, there is a risk of death or serious injury.

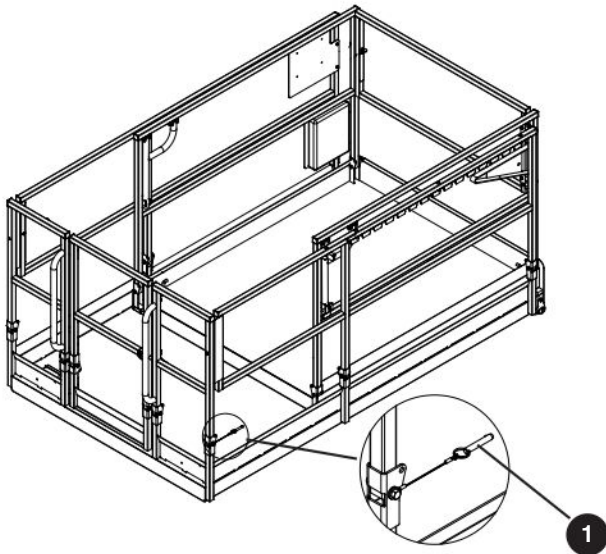

**1** Guardrail locking pin with lanyard—This pin is used to lock the guardrail in position.

### **WARNING**

Fall hazard. Fully lower the platform before you fold or unfold the guardrails. If you do not obey, there is a risk of death or serious injury.

### **WARNING**

Before you operate this MEWP, make sure that the guardrail system does not have loose or missing lock-pins. The guardrail system must be in the vertical position. Lock all pins correctly. An incorrectly locked guardrail can cause a fall, which can result in death or serious injury.

### 6.6-1 Fold the guardrail system down

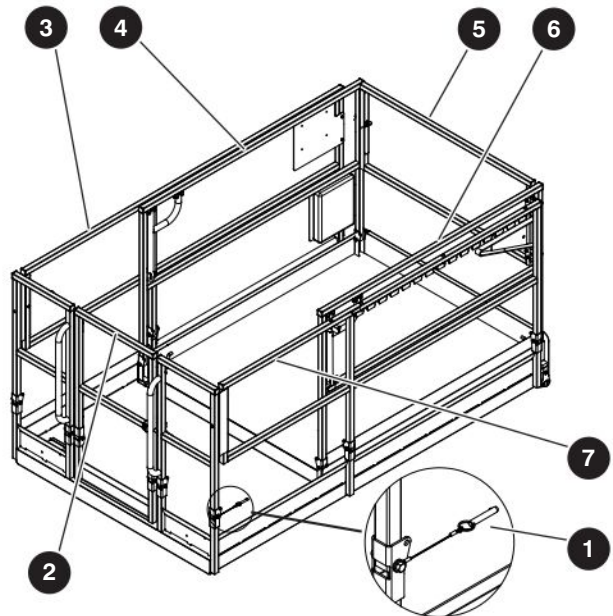

- 1** Lock-pin
- 2** Entrance
- 3** Left side
- 4** Left extension
- 5** Front
- 6** Right extension
- 7** Right side

1. Make sure that the MEWP is on firm, level ground.
2. Make sure you fully lower the platform.
3. Press the **emergency-stop** button on the base control console.
4. Turn the **main power disconnect** switch to the off position.

### **WARNING**

Fall Hazard. Use the three points of contact principle when you use the MEWP ladder to enter and exit the platform. If you do not obey, there is a risk of death or serious injury.

5. Use the MEWP ladder to enter the platform.
6. Close the gate.
7. Make sure you fully retract the extension platform.
8. Remove the **lock-pins** from the control console mounting bracket. Put the platform **control console** and **outrigger/generator control console** down on the platform floor.

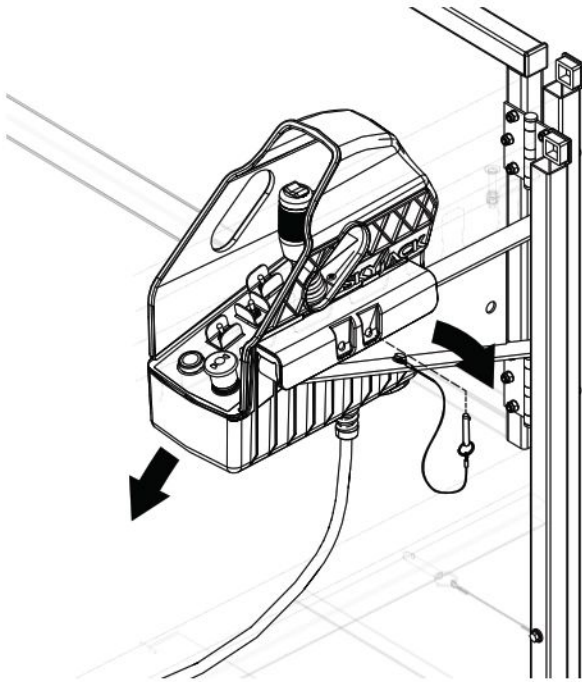

### **WARNING**

Fall hazard. To prevent a fall, keep away from the sides of the platform when you fold or unfold the guardrails. If you do not obey, there is a risk of death or serious injury.

9. Remove the locking pin that connects the front guardrail to the left extension guardrail.
10. Swing the front guardrail to the right extension.

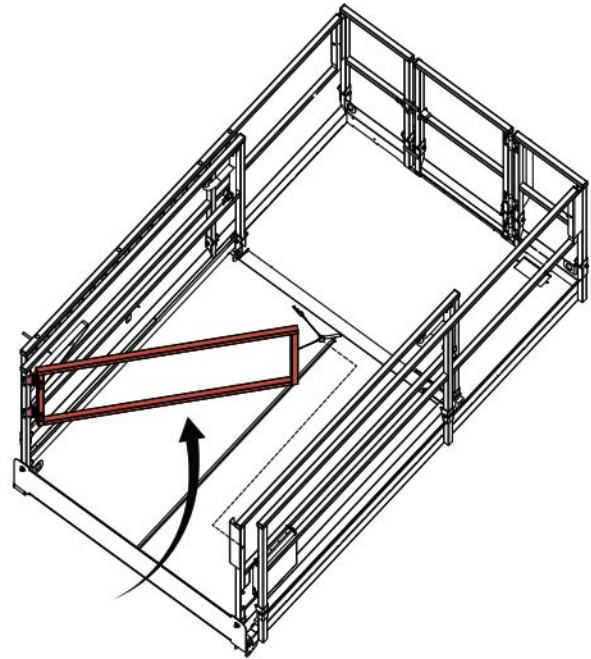

11. Use a tie-wrap to attach the front guardrail to the right side guardrail.
12. Remove the locking pins on the right-side extension guardrail.
13. Fold the right-side extension guardrail down with the front guardrail.
14. Remove the locking pins on the left-side extension guardrail.
15. Fold down the left-side extension guardrail.

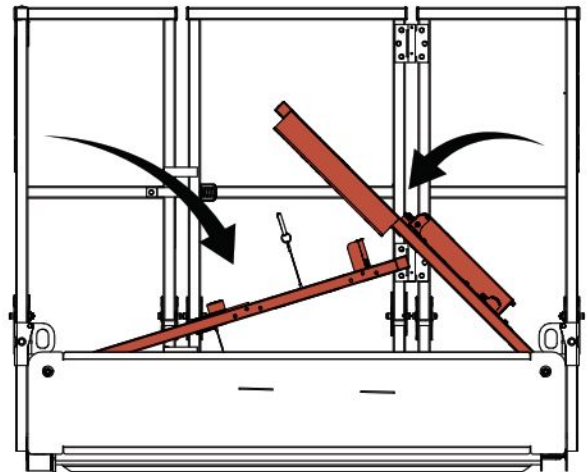



16. Remove the locking pins on the right side guardrail.
17. Fold down the right side guardrail.
18. Remove all the locking pins on the left side guardrail.
19. Fold down the left side guardrail.

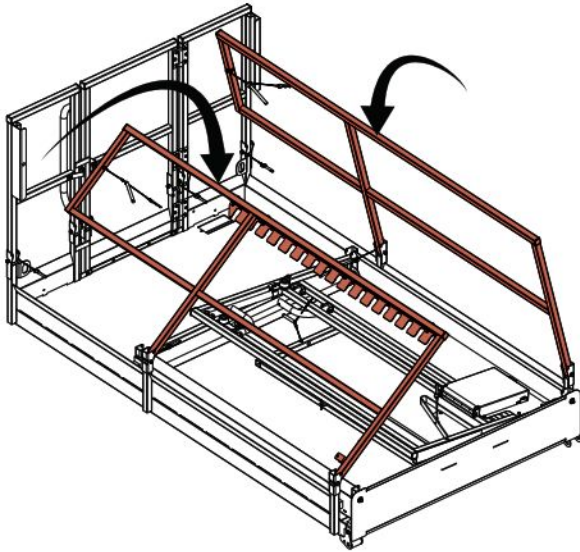

20. With the gate closed, remove all the locking pins on the entrance side guardrail.
21. Fold down the entrance side guardrail.

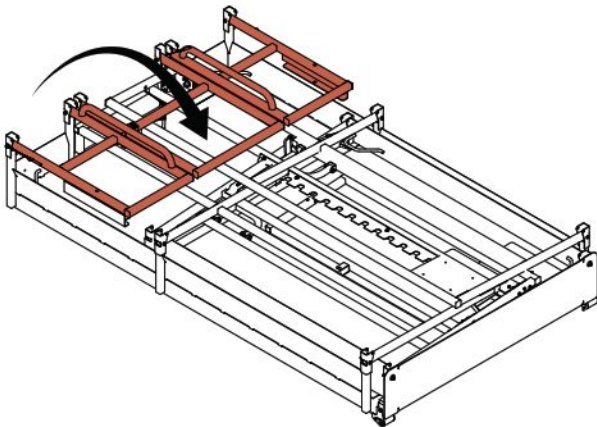

22. Use the MEWP ladder to exit the platform.

## 6.6-2 Unfold the guardrail system up

1. Make sure the MEWP is on firm, level ground.
2. Make sure you fully lower the platform.
3. Push the **emergency-stop** button on the base control console.
4. Turn the **main power disconnect** switch to the off position.

### **⚠ WARNING**

**Fall Hazard.** Use the three points of contact principle when you use the MEWP ladder to enter and exit the platform. If you do not obey, there is a risk of death or serious injury..

5. Use the MEWP ladder to enter the platform.
6. Close the gate.

### **⚠ WARNING**

**Fall hazard.** To prevent a fall, keep away from the sides of the platform when you fold or unfold the guardrails. If you do not obey, there is a risk of death or serious injury.

### **⚠ WARNING**

**Fall hazard.** Install each lock-pin correctly with the detent ball of each lock-pin fully through the guardrail. The guardrail system must be in the vertical position. An incorrectly locked guardrail can cause a fall, which can cause death or serious injury.

7. Unfold the entrance side guardrail.
8. Put in all locking pins to lock the entrance side guardrail in position.
9. Unfold the left side guardrail.
10. Put in all locking pins to lock the left side guardrail in position.
11. Unfold the right side guardrail.
12. Put in all locking pins to lock the right side guardrail in position.
13. Unfold the left-side extension guardrail.
14. Put in the locking pin to lock the left-side extension guardrail in position.
15. Unfold the right-side extension guardrail and the front guardrail.

16. Put the locking pin in the right extension to lock the right-side extension guardrail and the front guardrail in position.
17. Swing the front side guardrail forward.
18. Put in the locking pin to lock the front side guardrail in position.
19. Attach the platform control console and outrigger controls (optional equipment) to the front right of the platform. Lock them in position.

### **⚠ WARNING**

**Before you operate this MEWP, make sure that the guardrail system does not have loose or missing lock-pins. The guardrail system must be in the vertical position. Lock all pins correctly. An incorrectly locked guardrail can cause a fall, which can result in death or serious injury.**

## 6.7 Move the MEWP through a doorway

### **⚠ WARNING**

**Only do this procedure on level ground. If you do not obey, there is a risk of death or serious injury.**

1. Make sure the height/width of the doorway is sufficient to let the MEWP drive through.
2. Before you operate the MEWP, do a full inspection of the site (refer to [section 2.4](#)). Identify hazards in your work area.
3. Make sure the platform is fully lowered.
4. Disconnect and remove the platform control console. (refer to [section 6.5-1](#))
5. Fold the guardrails if it is necessary. Refer to [section 6.6](#) for the procedure on how to fold the guardrails.

### **⚠ WARNING**

**Crush hazard. Make sure that there are no personnel in the path you will travel. Tell personnel around the path before you move the MEWP. Use a second person to monitor the movement of the MEWP. Make sure that person stays at a safe distance. If you do not obey, there is a risk of death or serious injury.**

6. Connect the **platform control console cable** to the **electrical plug** in the engine compartment of the MEWP. Refer to [section 6.5](#).

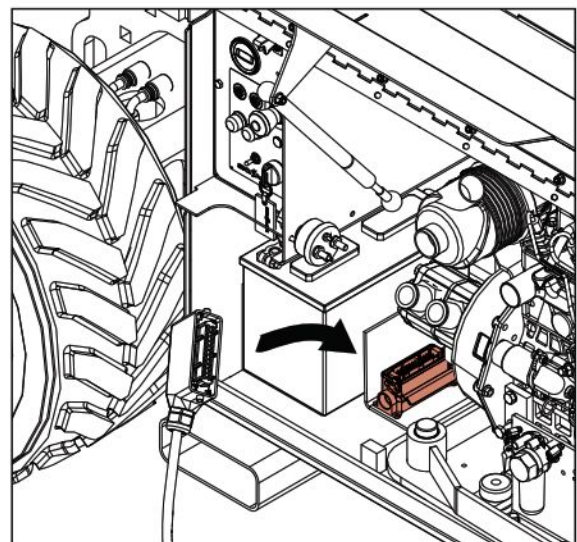

7. Stay behind the MEWP.
8. Make sure the **platform control console** points in the same direction as the front of the MEWP.
9. Turn the **main power disconnect** switch to the on position.
10. Pull the **emergency-stop** button on the base control console.
11. Turn the **idle/platform/base key** switch to the platform position.
12. Pull the **emergency-stop** button on the platform control console.
13. Start the engine.
14. Move the **inclined drive/level drive** switch to the inclined drive (low speed/high torque) position.
15. Move the **lift/off/drive** switch to the drive position.
16. Use as low a speed as is practical to drive the MEWP forward through the doorway.
17. Push the **emergency-stop** button when the MEWP is safely through the doorway.
18. Turn the **main power disconnect** switch to the off position.
19. Disconnect the **platform control console** from the engine compartment.

### **WARNING**

**Fall Hazard. Use the three points of contact principle when you use the MEWP ladder to enter or exit the platform. If you do not obey, there is a risk of death or serious injury.**

20. Use the MEWP ladder to enter the platform.

### **WARNING**

**Before you operate this MEWP, make sure that the guardrail system does not have loose or missing lock-pins. The guardrail system must be in the vertical position. Lock all pins correctly. An incorrectly locked guardrail can cause a fall, which can result in death or serious injury.**

21. Return the guardrails to the vertical position if folded. Refer to [section 6.6](#) for the procedure on how to fold the guardrails.

### **WARNING**

**Fall hazard. Make sure each lock-pin is correctly installed with the detent ball of each lock-pin fully through the hole. Failure to avoid this hazard could result in death or serious injury.**

22. Put the **platform control console** back onto the mounting bracket. Install the **lock-pin** in the mounting bracket.
23. Put the **control cable** into the railing clamp and install the **lock-pin**.

### **WARNING**

**Fall Hazard. Use the three points of contact principle when you use the MEWP ladder to enter or exit the platform. If you do not obey, there is a risk of death or serious injury.**

24. Use the MEWP ladder to exit the platform.
25. Connect the **platform control console cable** to the **electrical connector** below the platform.

## 6.8 Use the maintenance support

The maintenance support **1** is a mechanism on the scissor assembly. When it is in the correct position, it holds the scissor assembly and an empty platform.

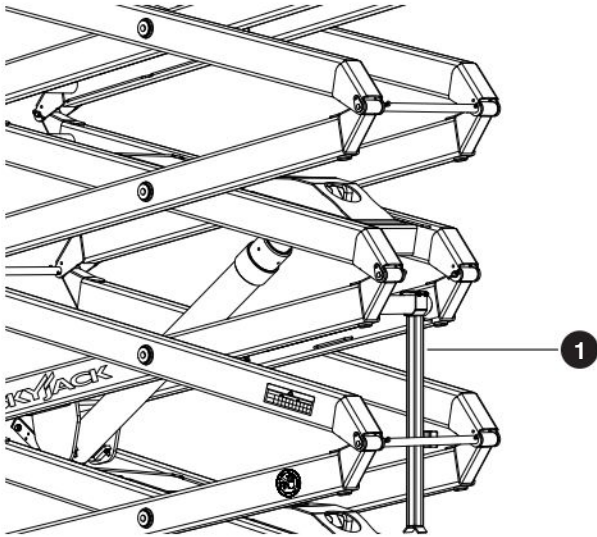

### **⚠ WARNING**

Use the maintenance supports when you do an inspection and/or maintenance or repairs in the confines of the lift mechanism. If you do not use the support, there is a risk of death or serious injury.

### **⚠ WARNING**

Look for overhead obstructions or other possible hazards around the MEWP when you raise the platform. Do not lower the platform unless the area below is clear of personnel and obstructions. If you do not obey, there is a risk of death or serious injury.

### **⚠ WARNING**

Crush hazard. Do not put parts of your body through the scissor assembly unless the maintenance support is correctly deployed. If you do not obey, there is a risk of death or serious injury.

### 6.8-1 Deploy the maintenance support

1. Remove all personnel and material from the platform.
2. Raise the platform until there is adequate clearance to deploy the maintenance support.
3. Deploy the maintenance support from the storage bracket into a vertical position.
4. Make sure that the scissors assembly area has no obstructions.
5. Lower the platform until the bottom end of the maintenance support touches the crossbar and the platform stops.
6. Turn the main power disconnect switch to the off position.

### **⚠ WARNING**

Look for overhead obstructions or other possible hazards around the MEWP when you raise the platform. Do not lower the platform unless the area below is clear of personnel and obstructions. If you do not obey, there is a risk of death or serious injury.

### 6.8-2 Store the maintenance support

1. Turn the main power disconnect switch to the on position.
2. Retract the platform until there is adequate clearance to raise the maintenance support.
3. Retract the maintenance support into the storage bracket.
4. Fully lower the platform.

## 6.9 Refuel

### WARNING

Do not start the MEWP if you smell gas. Lock and tag the MEWP, and remove it for servicing. If you do not obey, there is a risk of death or serious injury.

### WARNING

Do not operate a MEWP that does not function correctly. Lock and tag the MEWP, and remove it for servicing. Only a qualified service technician must repair the MEWP. If you do not obey, there is a risk of death or serious injury.

### WARNING

Explosion hazard. Only refuel the MEWP in a well-ventilated area, away from open flame and other sources of ignition, approved by your employer and/or supervisor. Always have an approved fire extinguisher that you can easily access. If you do not obey, there is a risk of death or serious injury.

### WARNING

Explosion hazard. Do not smoke in an area where MEWPs are kept or refueled. If you do not obey, there is a risk of death or serious injury.

### IMPORTANT

Before you use the MEWP, make sure that there is sufficient fuel for the estimated task.

#### 6.9-1 Refuel the MEWP with gasoline or diesel

### IMPORTANT

For gasoline engines, use unleaded gasoline with an octane rating of 87 or higher. For diesel engines, use ultra-low sulfur diesel. Refer to the information on the fuel tank.

1. Put all the power connections in the off position. This includes the engine.
2. Push all the **emergency-stop** buttons, and turn the **main power disconnect** switch to the off position.

### WARNING

Environmental hazard. Immediately remove gasoline, diesel fuel, engine oil, and hydraulic fluid spills and leaks with rags. Discard these rags in accordance with national, state/provincial/territorial, and local regulations. Spilled fluids can damage the environment. When spilled fluids go into the water (for example, a sewage system, streams, rivers, or other surface water), they can kill aquatic life.

3. Remove the fuel cap.
4. Carefully fill the fuel tank. Make sure that there are no spills. At the same time, look at the fuel gauge on the side of the tank. The fuel gauge indicator must not go above the F (full) mark.
5. Put the fuel cap back on and make sure it closes tightly.
6. Do an inspection of the fuel system for leaks. Clean away spilled fuel.
7. Discard the wipes or rags in an approved container.

#### 6.9-2 Replace the propane cylinder (dual fuel)

### WARNING

Obey all national, state/provincial/territorial, and local health and safety rules for propane handling. If you do not obey, there is a risk of death or serious injury.

### WARNING

When you replace a liquid propane gas cylinder, do an inspection of all the connections for damage or missing parts. If you do not obey, there is a risk of death or serious injury.

### WARNING

Explosion hazard. Do not start the MEWP if you smell liquid propane gas. Liquid propane gas is heavier than air. It collects in low areas. A flame or spark can cause a fire or explosion. Lock and tag the MEWP for servicing or repair. If you do not obey, there is a risk of death or serious injury.



### 6.9-3 Remove the propane cylinder

1. Stop the engine.
2. Push the **emergency-stop** button on the base control console.
3. Turn the **propane cylinder valve** clockwise to stop the fuel supply to the engine.
4. Pull the **emergency-stop** button. Start the engine and let it stop by itself.
5. Move the **fuel** switch to the liquid propane gas position.
6. Start the engine again to make sure the fuel lines are empty.
7. Push the **emergency-stop** button.
8. Turn the propane tank hose fitting counterclockwise to detach the coupling. Disconnect the hose from the empty propane cylinder.
9. Pull on the metal clips to loosen the two propane cylinder straps. Disconnect the straps from the hooks.
10. Remove the empty propane cylinder.

### 6.9-4 Install the propane cylinder

1. Push the **emergency-stop** button on the base control console.
2. Put the propane cylinder on the propane mounting bracket. Make sure the metal peg goes through the hole on the propane cylinder rim.
3. Reconnect the propane cylinder straps to the hooks and fasten them tightly.
4. Attach the hose to the new propane cylinder. Turn the fitting clockwise to tighten it.
5. Apply mild soapy water to the propane hose connection.
6. Open the valve one quarter-turn counterclockwise. Do an inspection for gas leaks.
7. If there are no gas leaks, fully open the **propane cylinder valve**.
8. Wipe off the soapy water after the inspection is complete.



















# Section 7 – Technical Specifications

## 7.1 Standard and optional equipment

Models	SJ6826 RT	SJ6832 RT
<b>Standard Equipment</b>		
Platform controls		*
Base controls		*
4WD		*
23.1 kW Kubota DF972 dual fuel - gasoline/propane engine		*
Manual extension platform		*
Load sensing system		*
AC outlet on platform		*
Tilt sensing system with alarm and drive/lift cutout		*
Scissor guards		*
Swing out engine tray		*
Disc brakes		*
Manual brake release		*
Fall protection anchorage(s)		*
Hinged railing system		*
Operator horn		*
Spring loaded full height gate at rear		*
Forklift pockets, tie down/lifting lugs		*
Foam filled low profile grip lug tires		*
Hourmeter		*
Color coded and numbered wiring system		*
Hydraulic oil level indicators		*
All motion audible alarm		*
<b>Optional Equipment</b>		
Flashing light		*
18.5 kW Kubota D902 diesel engine		*
Heavy duty pipe rack		*
Non marking grip lug foam-filled tires		*
3.5 kW hydraulic generator		*
Cold Weather start package		*
Bio oil		*
Work lights		*
Positive air shutoff		*
Tool caddy		*
Outriggers		*
Diesel scrubber		*
Elevate Telematics		*
Secondary Guarding Lift Enable (SGLE)		*

1967AA

## 7.2 Owner's annual inspection record

												
										Model _____		SN _____
Inspection Date			20	20	20	20	20	20	20	20	20	
Inspector Signature												

**⚠ WARNING**

Do not use the MEWP if there is no inspection recorded in the last 13 months. If you do not obey, there is a risk of death or serious injury.

**IMPORTANT**

The Owner's Annual Inspection Record on the scissor assembly must be filled out after an annual inspection is completed.

## 7.3 Specifications

Models	SJ6826 RT	SJ6832 RT
Weight (Without Outriggers)*	2930 kg (6460 lb)	3443 kg (7590 lb)
Weight (With Outriggers)*	3440 kg (7570 lb)	3641 kg (8030 lb)
Overall Width	1.765 m (69.5 in)	
Overall Length (Platform Retracted)	2.720 m (107 in)	
Overall Length (Platform Extended)	4.110 m (162 in)	
Platform Length, Inside (Platform Retracted)	2.440 m (96 in)	
Platform Length, Inside (Platform Extended)	3.900 m (153 in)	
<b>Height</b>		
Working Height	9.7 m (31.7 ft)	11.5 m (37.6 ft)
Platform Elevated Height	7.8 m (25.7 ft)	9.6 m (31.6 ft)
Stowed Height (Railings Up)	2.370 m (93.5 in)	2.510 m (99 in)
Stowed Height (Railings Down)	1.620 m (63.5 in)	1.750 m (69 in)
Drive Height (Maximum)	FULL	
<b>Standard operating times</b>		
Lift Time (No Load)	32 - 36 sec	32 - 36 sec
Lower Time (No Load)	46 - 50 sec	44 - 48 sec
Lift Time (Rated Load)	34 - 38 sec	37 - 41 sec
Lower Time (Rated Load)	34 - 38 sec	34 - 38 sec
Lift Pressure	172-193 bar (2500-2800 psi)	
<b>Chassis</b>		
Normal Drive Speed	5.78 - 6.10 km/h (3.59 - 3.79 mph)	
Elevated Drive Speed	0.52 - 0.61 km/h (0.32 - 0.38 mph)	
Gradeability (Ramp Angle)	50%	40%
Tires (Foam Filled)	30.5 cm x 66 cm (12 in x 26 in)	
<b>Engine (RPM)</b>		
Kubota Diesel/Dual Fuel	3500 (High Throttle)/2050 (Low Throttle)	
Fuel Tank Capacity	80 L (21 gal)	
<b>Hydraulic oil</b>		
Type	ATF Dexron III	
Tank Capacity	71 L (18.8 gal)	
Guaranteed Sound Power Level	96 dB(A)	
Emission sound pressure level at platform does not exceed 70 dB(A).		
Vibration - acceleration to which operator's body is subjected does not exceed 0.5 m/sec <sup>2</sup> .		

\* Weights are approximate; refer to serial nameplate for specific weight.

1704AB

## 7.4 Maximum platform capacities (evenly distributed)

Models	Wind Rating	Total Platform Capacity		Extension Platform Capacity		Manual Side Force	Tilt Cutout Setting (side-to-side x front-to-back)
SJ6826 RT	12.5 m/sec (41 ft/sec)	567 kg (1250 lb)	4 Persons	136 kg (300 lb)	1 Person	400 N (90 lbf)	2.5° x 4.5°
SJ6832 RT		454 kg (1000 lb)	4 Persons				

1903AA

### NOTE

Occupants and materials are not to exceed the rated load. Refer to the capacity label at the sides of the platform for additional information and models equipped with options.

## 7.5 Environment

Model	SJ6826 RT	SJ6832 RT
Electromagnetic Compatibility (EMC)	Meets requirements of ISO 13766-1:2018 and CAN/CSA CISPR 12-10	
Hazardous Location Rating	MEWP not rated for hazardous locations with potentially flammable gases, explosive gases or particles	
Sound Pressure Level (ISO 3744)	70 dB	
Guaranteed Maximum Sound Power Level (ISO 4871)	96 dB	
Whole-body Vibration on Platform	≤ 0.5 m/s <sup>2</sup>	
Operating Temperatures		
Standard	-20°C (-4°F) to +40°C (+104°F)	
Cold Weather Package	Below -10°C (+14°F)	
Arctic Weather Package	Below -18°C (0°F)	

1904AA

## 7.6 Floor loading pressure

Models		Weights				Pressures			
		MEWP Weight		Max weight per wheel/outrigger pad		LCP**		OFL**	
		kg	lb	kg	lb	kPa	psi	kg/m <sup>2</sup>	psf
SJ6826 RT on tires (foam-filled only)	Min*	2930	6460	1400	3090	1130	163	620	125
	Max*	3440	7570	1630	3600	1310	190	730	150
SJ6826 RT on outrigger pads	Min*	3436	7573	1400	3090	280	40	590	119
	Max*	4003	8823	1630	3600	320	46	680	138
SJ6832 RT on tires (foam-filled only)	Min*	3443	7590	1675	3693	1350	195	720	146
	Max*	3897	8589	1860	4100	1500	216	920	166
SJ6832 RT on outrigger pads	Min*	3553	8027	1675	3693	330	47	620	126
	Max*	4095	9027	1860	4100	370	52	700	142

1852AA

- \* **Min:** Minimum MEWP weight (Unloaded platform, no options/attachments)  
**Max:** Maximum MEWP weight (Platform loaded to capacity with options/attachments)

**Wheel** is the weight that can be experienced on one wheel.

**Note:** This is more than 25% of the machine weight due to possible weight distribution over the machine and platform.

- \*\* **LCP:** Local Concentrated Pressure is a measure of how hard the MEWP presses on the area in direct contact with the floor/tire.  
**OFL:** Overall Floor Load (Pressure) is a measure of the average load the MEWP imparts on the whole surface directly underneath the chassis. This has been calculated by dividing the MEWP weight by the overall floor area occupied by the MEWP (on wheels).

**Note:** The floor covering (e.g., tile, carpet, etc.) or the structure (e.g., beams) of the operating surface must be able to withstand more than the values indicated above.

**Note:** The LCP or OFL that an individual surface can withstand varies from structure to structure and is generally determined by the engineer or architect for that particular structure.

### NOTE

The LCP or OFL that an individual surface can withstand varies from structure to structure and is generally determined by the engineer or architect for that particular structure.

### WARNING

**Do not use tires other than the tires that Skyjack specifies for this MEWP. Do not mix different types of tires or use tires that are not in good condition. Only replace the tires with the same types that are approved by Skyjack. The use of other tires can make the MEWP less stable. If you do not obey, there is a risk of death or serious injury.**





# Section 8 – Labels



Red  
**DANGER.**



Orange  
**WARNING.**

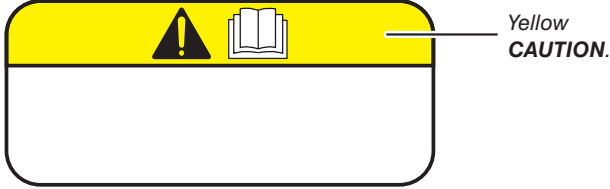

Yellow  
**CAUTION.**

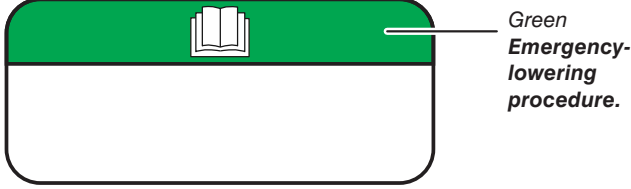

Green  
**Emergency-  
lowering  
procedure.**

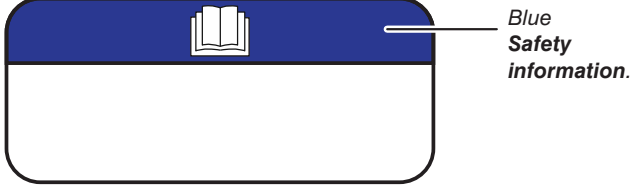

Blue  
**Safety  
information.**

# 8.1 Engine compartment

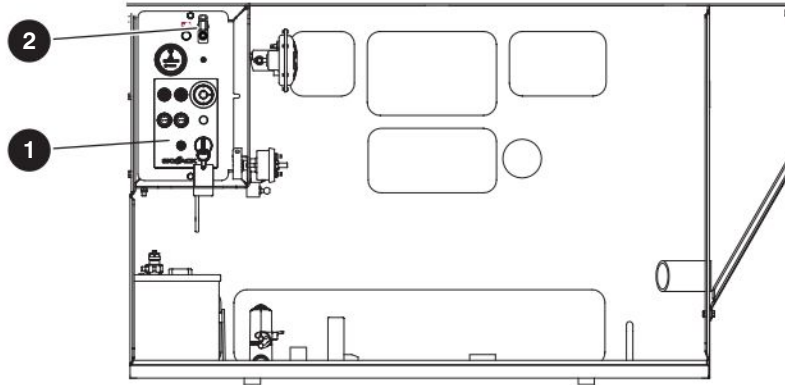

Description

Label Pictorial

## 1 Base control console

- Push to reset ground circuit breaker.
- Push to reset power circuit breaker.
- Push to stop engine and disable controls (emergency-stop).
- Light indicates controls enabled.
- Push and hold to start engine.
- Push and hold to operate choke (dual fuel) or glow plugs (diesel).
- Select gasoline or propane. Light indicates glow plug operation (diesel).
- Select to raise or to lower platform.
- Select to enable platform controls, to allow engine run with no controls active or to enable base control console.
- Read the operating manual.

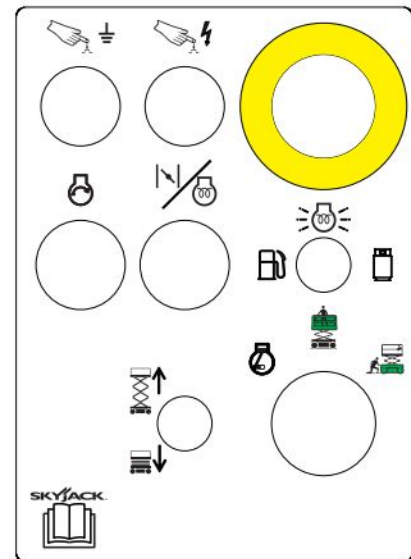

## 2 Positive air shutoff (optional equipment)

Select the **positive air shut-off switch** (optional) to stop the air supply to the engine.



**Engine compartment (continued)**

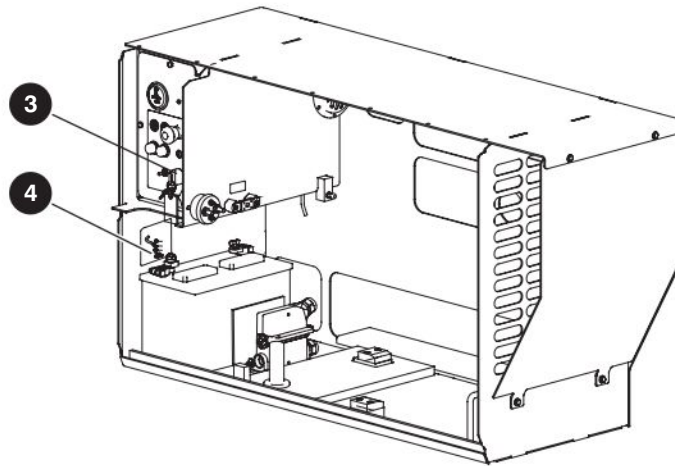

Description

Label Pictorial

**3 Main power disconnect switch**

- Turn the switch clockwise to turn the power on.
- Turn the switch counterclockwise to turn the power off.
- Use a padlock to lock the switch in position.

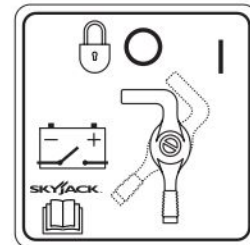

**4 Battery fuse assembly**

Assemble fuse as shown. Torque to value indicated.

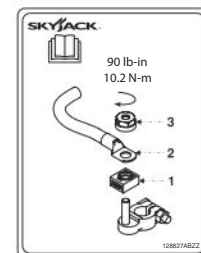

## 8.2 Right side

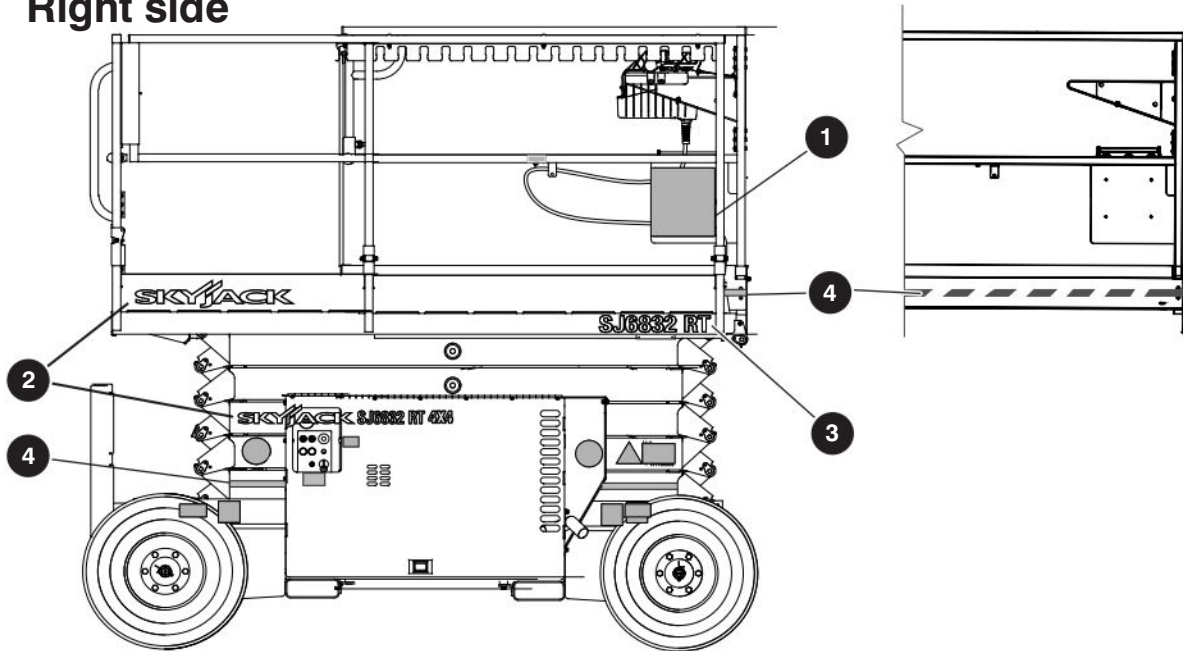

Description

Label Pictorial

### 1 Hazard identification/manual storage box

- Read and understand the outlined risks associated with this MEWP prior to operation.
- Indicates location of operating manual.



### 2 Skyjack logo



### 3 Model number\*

Product Identifier

\*Model number will vary and may not be as shown.

SJ6832 RT

### 4 Caution tape stripe



Right side (continued)

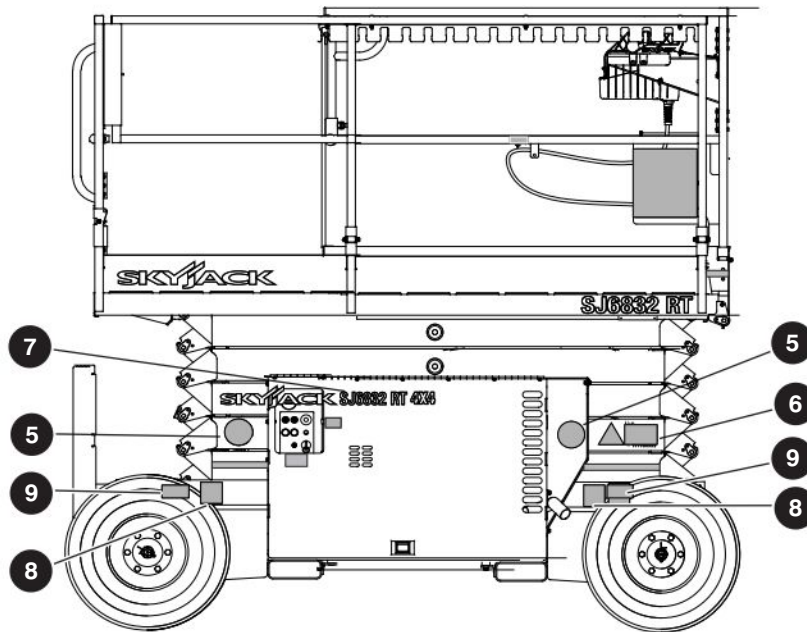

Description

Label Pictorial

**5 Keep clear**

Keep clear. Stay away from MEWP when in operation.



**6 Annual inspection**

Ensure that MEWP has received annual inspection prior to operation.

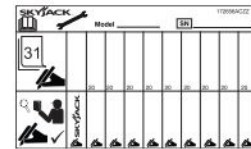

**7 Model number\***

Product Identifier

\*Model number will vary, may not be as shown.

**SJ6832 RT 4X4**

**8 Tip-over hazard**



**9 Wheel specifications**

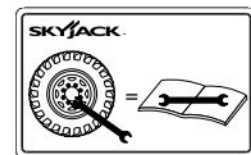

Right side (continued)

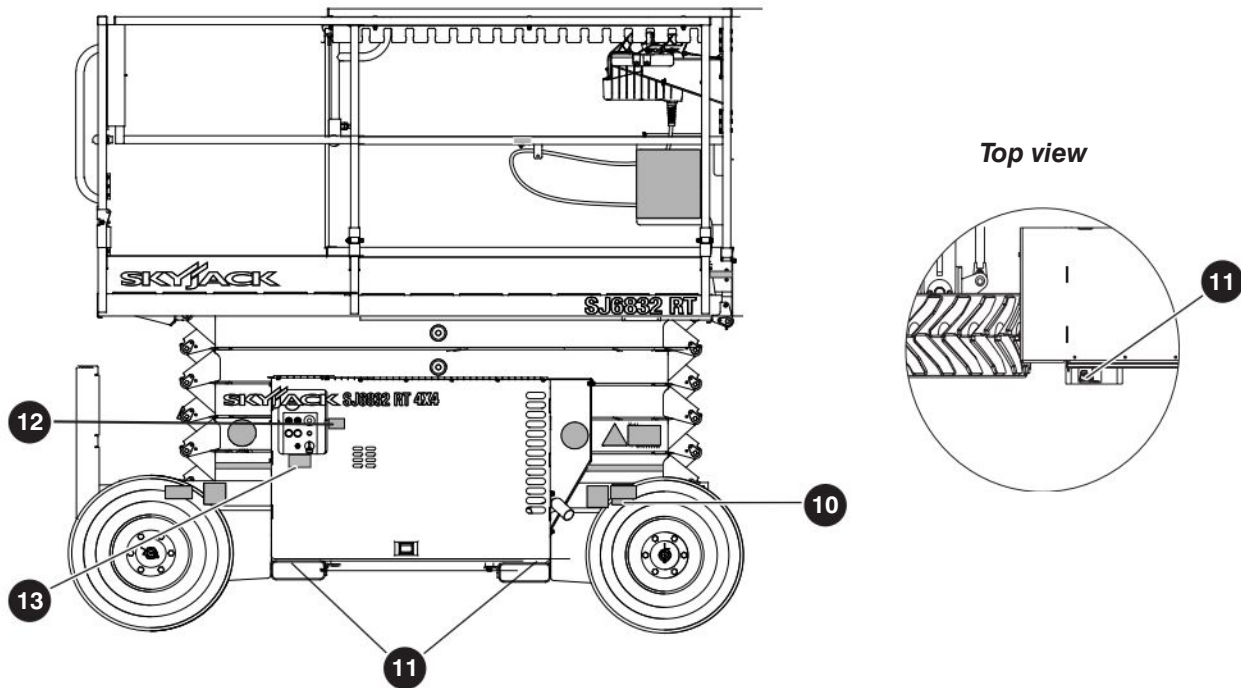

Description

Label Pictorial

**10 Wheel load**

Indicates rated wheel load.

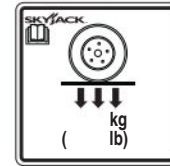

**11 Forklift lift location**

Insert fork fully into forklift lift location to lift the MEWP.



**12 Elevate™ – Powered by Trackunit (optional equipment)**

This MEWP is equipped with additional functionality.



**13 QR code**

This code gives you fast access to the MEWP documentation, and the live MEWP data supplied by ELEVATE telematics (optional equipment).

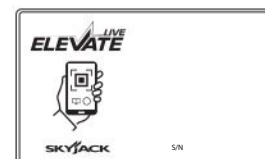





Front side (continued)

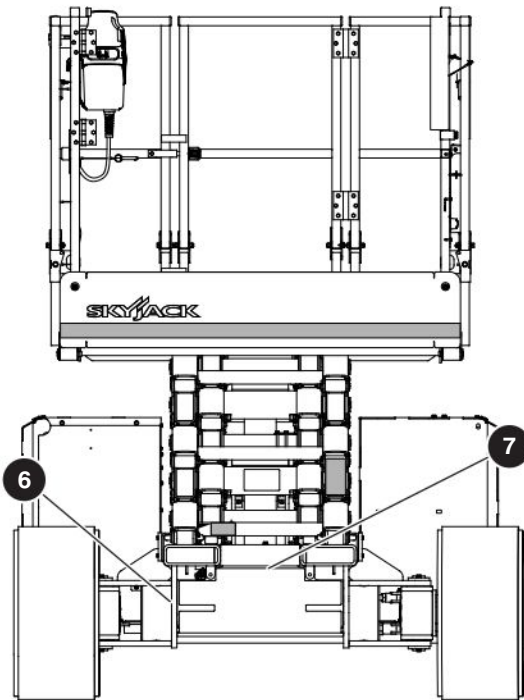

Description

Top view

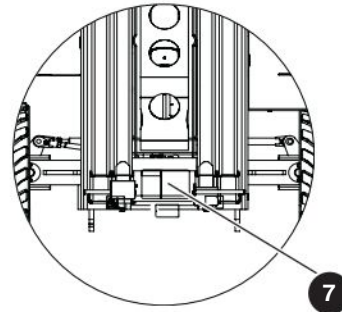

Isometric view

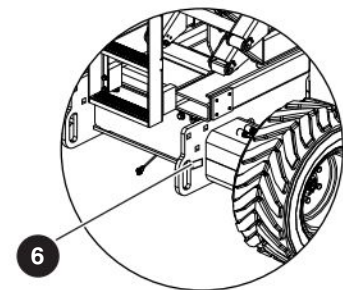

Label Pictorial

**6 Lift and tie-down points**

Only use these points for lifting or tying down.



**7 Maintenance support procedure**

Refer to the operation manual.

1. Remove all personnel and material from the platform.
2. Raise platform until there is adequate clearance to deploy the maintenance support.
3. Deploy the maintenance support from the storage bracket into a vertical position. Lower platform until the bottom end of maintenance support rests on the lower cross bar.
4. Maintenance support is now secured.
  - a. Turn Main power disconnect switch to off position.
  - b. Perform inspection/maintenance.
5. Turn Main power disconnect switch to on position.
6. Raise platform until there is adequate clearance to retract the maintenance support.
7. Retract the maintenance support up and place into storage bracket.
8. Fully lower the platform.

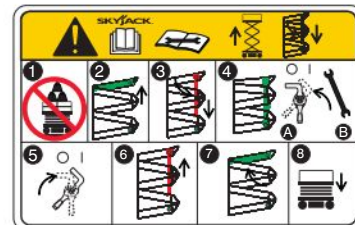

### 8.4 Left side

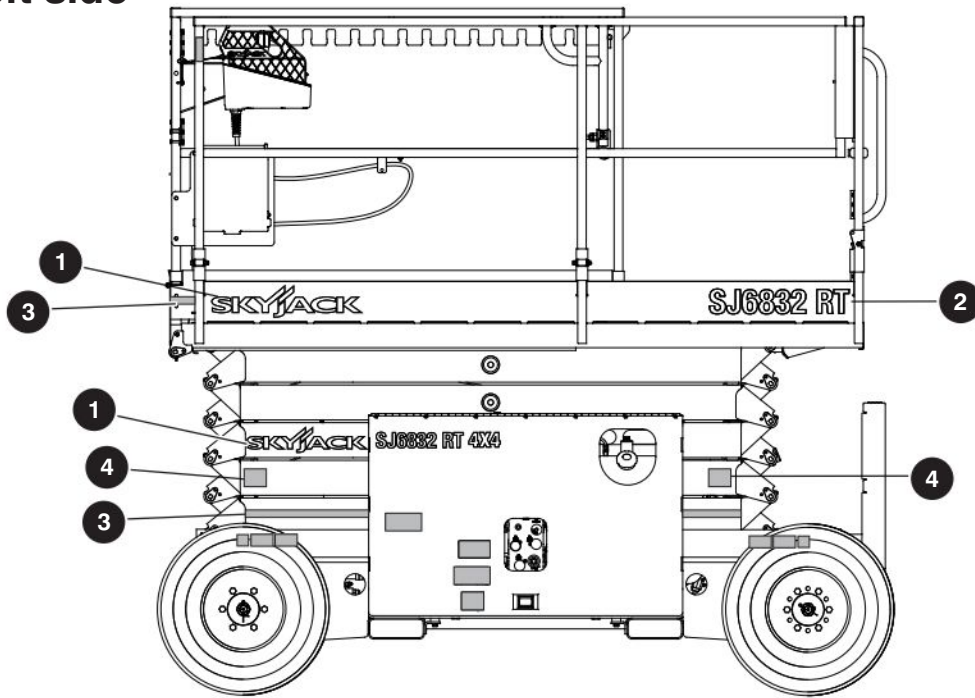

Description

Label Pictorial

1 Skyjack logo



2 Model number\*

Product Identifier

\*Model number will vary, may not be as shown.

SJ6832 RT

3 Caution tape stripe



4 Keep clear

Keep clear. Stay away from MEWP when in operation.



Left side (continued)

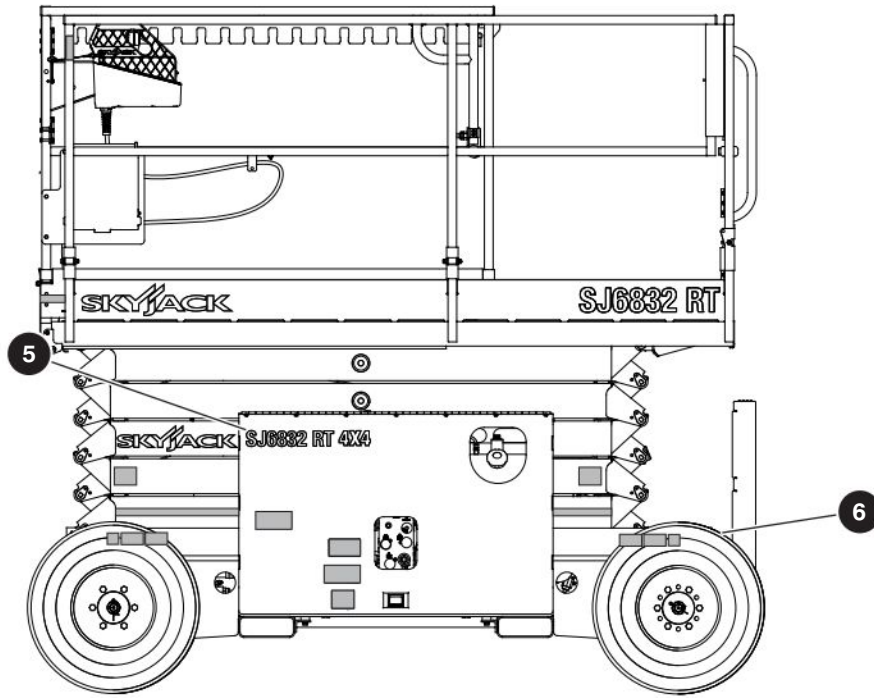

Description

Label Pictorial

**5 Model number\***

Product Identifier

\*Model number will vary, may not be as shown.

**SJ6832 RT 4X4**

**6 Connect AC supply**

Connect AC Supply here.

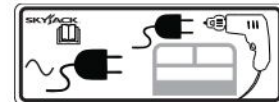

## Left side (continued)

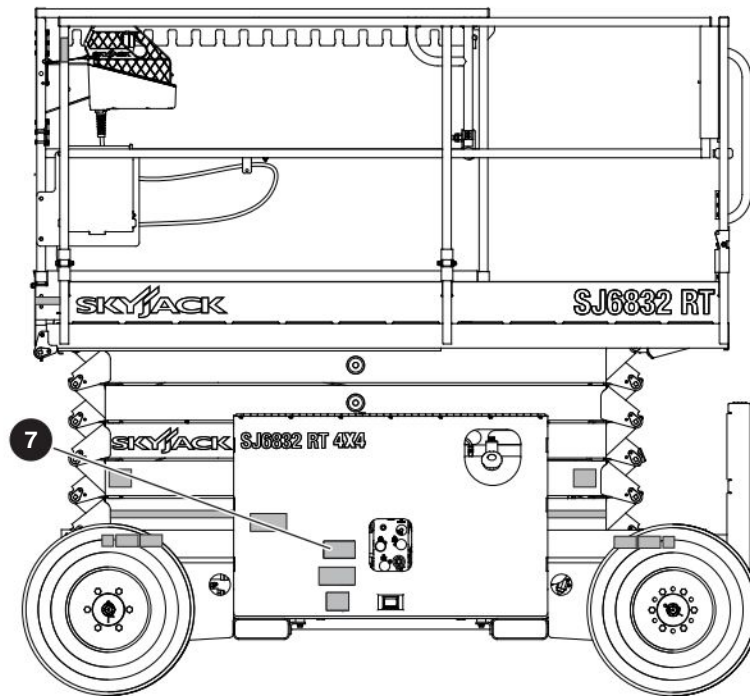

Description

Label Pictorial

### 7 Winch and tow procedure

Refer to the operation manual.

1. Use wheel chocks or blocks at the front of the wheels and behind them to prevent MEWP movement.
2. Turn the **main power disconnect** switch to the off position.
3. Find the drive manifold at the rear side of the base.
4. Turn the freewheeling valve counterclockwise to the fully open position.
5. Push the plunger of the brake auto-reset valve.
6. Continuously push and release the knob of the hand pump until the pressure gauge (optional) shows 21 bar (300 psi). Do not go higher than 24 bar (350 psi). The brake is released.
7. Push, winch, or tow the MEWP to the necessary location.
8. Put the MEWP on a firm, level surface. Use wheel chocks or blocks at the front of the wheels and behind them to prevent MEWP movement.
9. Pull out the **plunger** of the brake auto-reset valve to re-engage the brakes.
10. Turn the freewheeling valve clockwise until it is closed tightly.



Left side (continued)

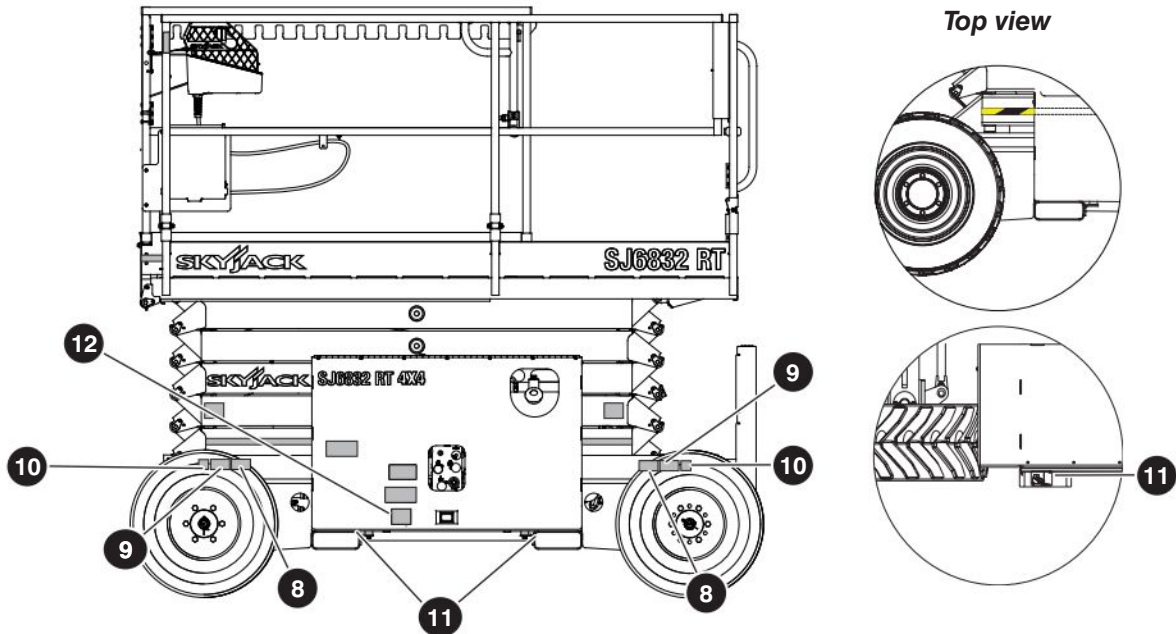

Description

Label Pictorial

**8 Foam filled tire**

Indicates foam filled tire.



**9 Wheel specifications**

Refer to manual for wheel type, offset, pressure and torque.

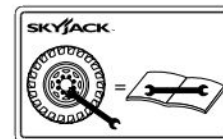

**10 Wheel load**

Indicates rated wheel load.

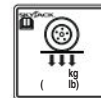

**11 Forklift lift location**

Insert fork fully into forklift lift location to lift the MEWP.



**12 Emergency-lowering procedure**

Refer to the operation manual.

1. Turn Main power disconnect switch to off position.
2. To open the lift cylinder holding valves located at the bottom of each cylinder:  
if higher reach required, use emergency-lowering rod located on the top of the base to:
  - a. push
  - b. turn knurled knob counterclockwise.
3. To lower the platform, pull out emergency-lowering valve located on the outside of the hydraulic tray.

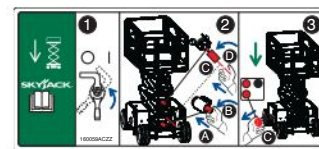



## 8.5 Hydraulic/fuel compartment

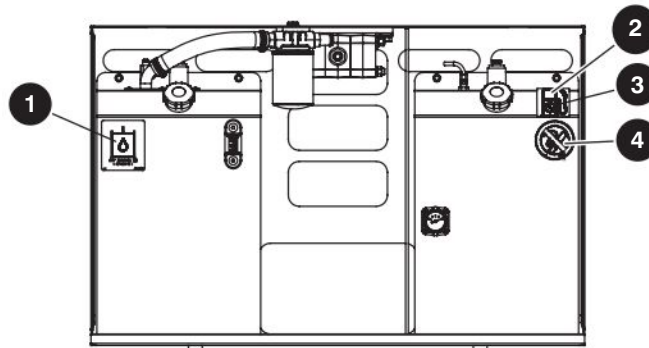

Description	Label Pictorial
<p><b>1 Hydraulic oil ATF Dexron III</b> Replace hydraulic fluid with ATF Dexron III only.</p>	
<p><b>2 Diesel (optional equipment)</b> Use diesel fuel only.</p>	
<p><b>3 Unleaded fuel</b> Use unleaded gasoline only.</p>	
<p><b>4 No smoking</b> Do not smoke near this location.</p>	

## 8.6 Rear side

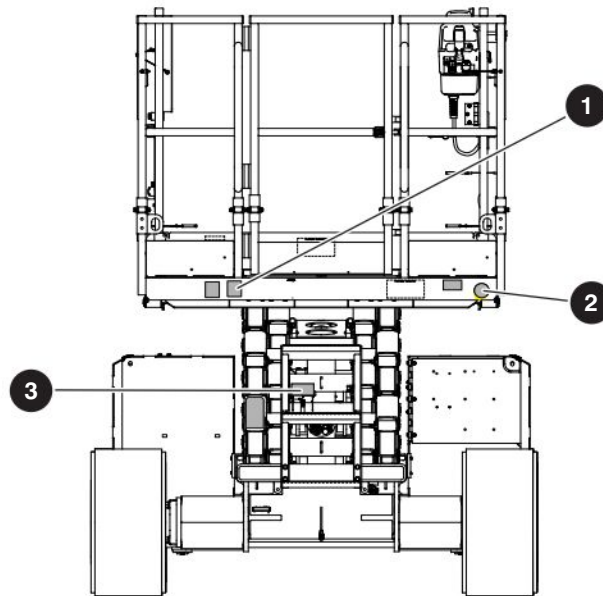

Description

Label Pictorial

### 1 Operator's daily inspection

- Refer to the Operating manual.
- Perform visual inspection and function tests at the beginning of each shift. Refer to [Section 4: Maintenance and Inspection Schedule](#).



### 2 No jewelry

Caution—Do not wear jewelry.



### 3 Warning—Do not alter

Do not alter or disable limit switches or other safety devices.



Rear side (continued)

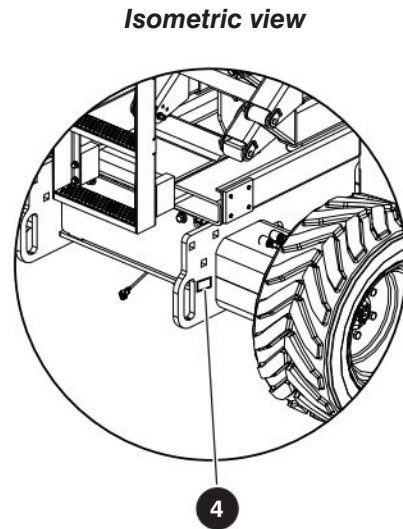
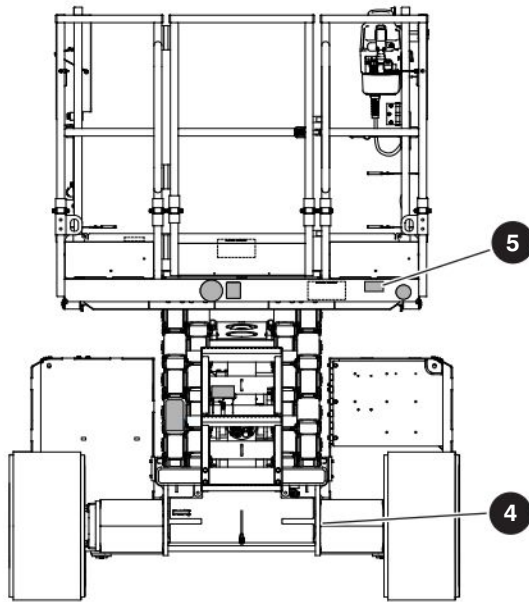

Description

Label Pictorial

**4 Lift and tie-down points**

Only use these points for lifting or tying down.



**5 Warning–California Proposition 65**

Cancer and Reproductive Harm–  
<https://www.p65warnings.ca.gov/>.



# 8.7 Propane tank

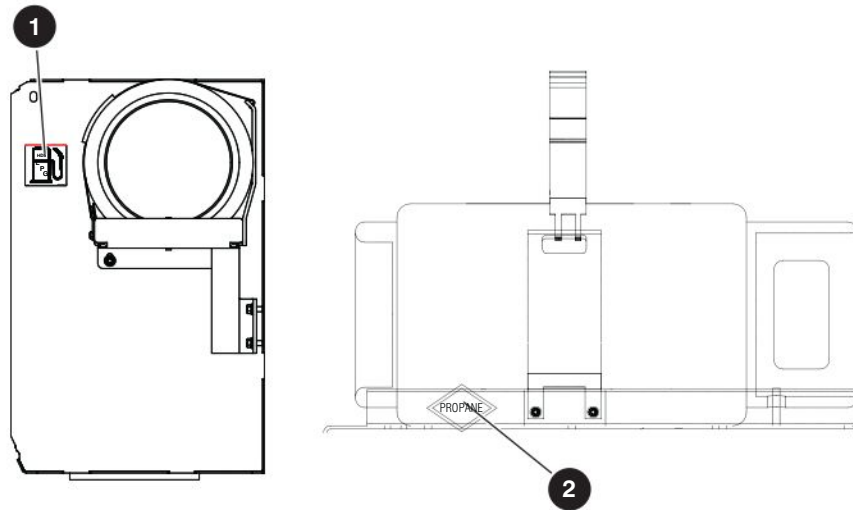

Description

Label Pictorial

**1 Liquid propane**

Use liquid propane only.

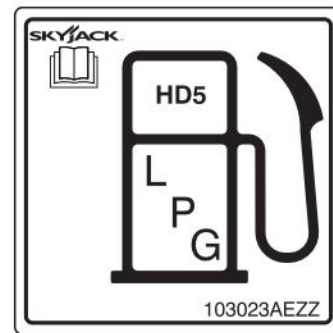

**2 Propane**

Use liquid propane only.



## 8.8 Platform view

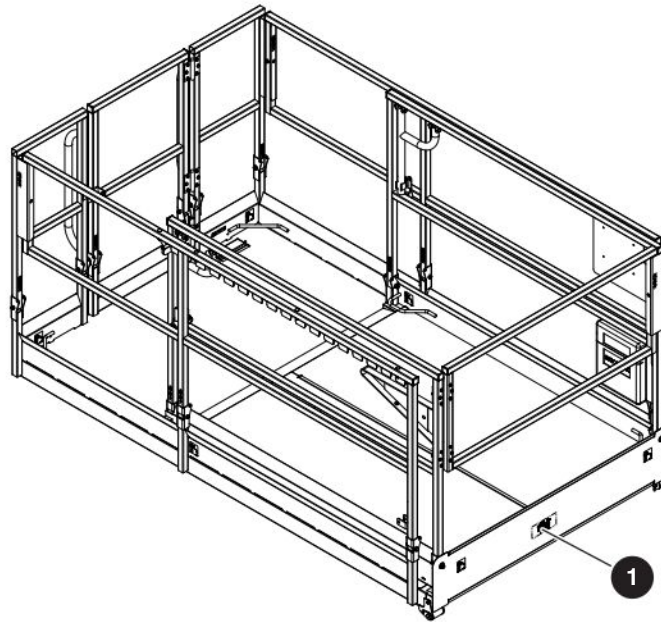

Description

Label Pictorial

### 1 Platform capacity

- Platform capacity label for SJ6826 RT and SJ6832 RT respectively.
- Rated work load in each configuration is as shown.
- Rated work load includes the weight of both personnel and material.
- Maximum number of people in each configuration is as shown. Do not exceed total weight or maximum number of people. Load platform uniformly.

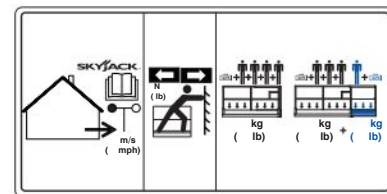

Platform view (continued)

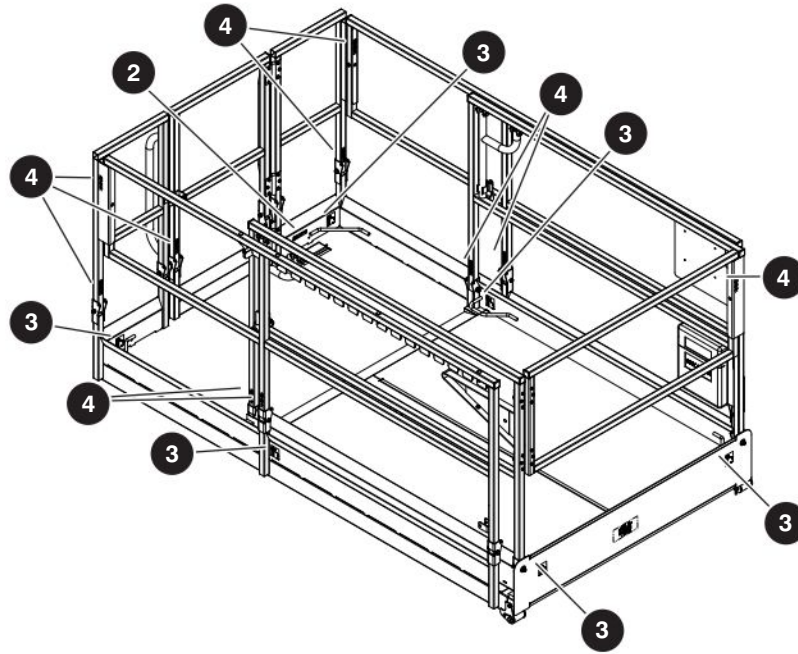

Description

Label Pictorial

**2 Connect AC supply**

Connect AC supply here.

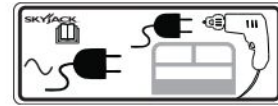

**3 Fall protection anchorage**

- Attach body harness lanyards of each occupant to fall protection anchorage points.
- Rated for one (1) person per anchorage.



**4 Railing pins (vertical)**

WARNING! Falling Hazard. Ensure hinged railing is pinned.



## 8.9 Platform control console

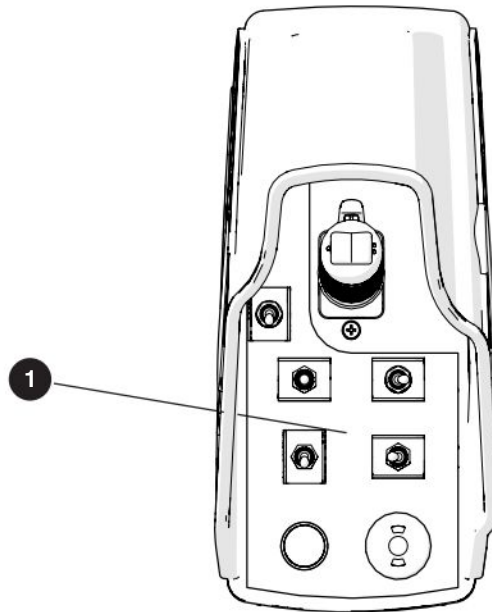

Description

Label Pictorial

### 1 Platform control console

- Squeeze trigger to enable controller.
- Operate rocker switch to steer.
- Move controller forward to raise or backward to lower platform.
- Move controller forward to drive forward or backward to drive reverse.
- Select either drive mode with low speed (high torque) or drive mode with high speed (low torque).
- Select either lift mode or drive mode.
- Select either low or high engine throttle speed.
- Select and hold to start engine.
- Select and hold to operate choke (dual fuel) or glow plugs (diesel).
- Push to sound horn.
- Push to stop engine and disable controls (emergency-stop).
- Light indicates controls enabled.
- Read the operating manual.

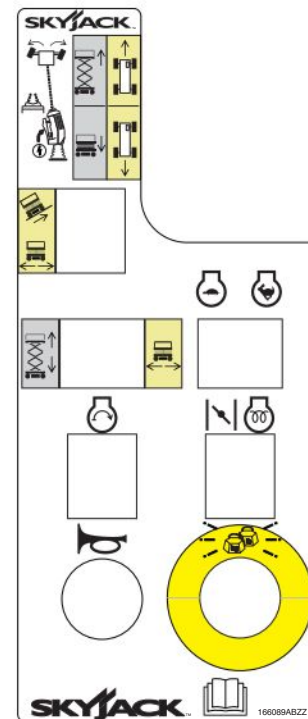



## 8.10 Lift cylinders

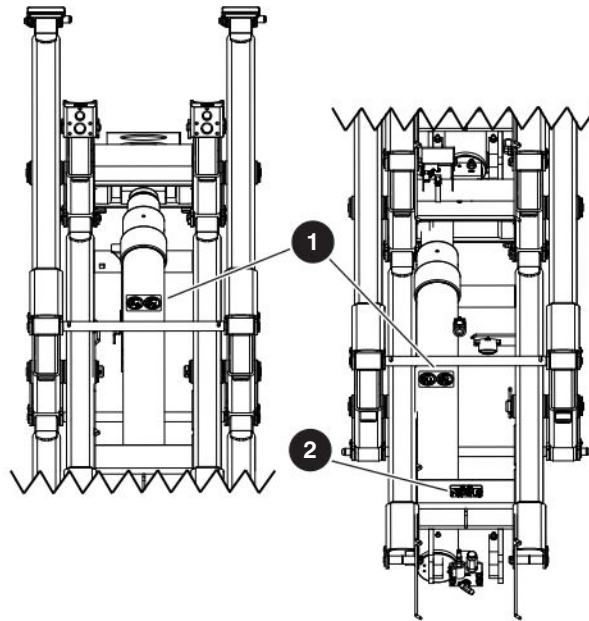

Description

Label Pictorial

### 1 Orifice installed

Orifice installation warning



### 2 Emergency-lowering procedure

Refer to the operation manual.

1. Turn Main power disconnect switch to off position.
2. To open the lift cylinder holding valves located at the bottom of each cylinder:  
if higher reach required, use emergency-lowering rod located on the top of the base to:
  - a. push
  - b. turn knurled knob counterclockwise.
3. To lower the platform, pull out emergency-lowering valve located on the outside of the hydraulic tray.

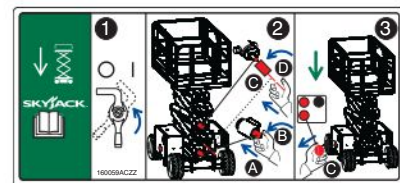

## 8.11 Outriggers (optional equipment)

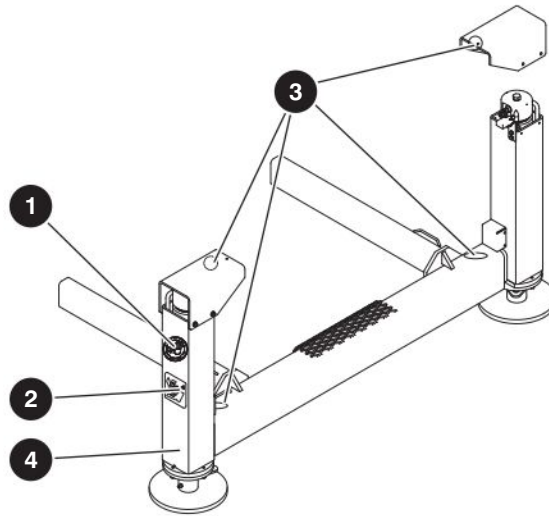

Description	Label Pictorial
<p><b>1 Keep clear</b> Keep clear. Stay away from MEWP when in operation.</p>	
<p><b>2 Crush hazard</b> Warning–Crushing hazard</p>	
<p><b>3 Warning–Do not alter</b> Do not alter or disable limit switches or other safety devices.</p>	
<p><b>4 Outrigger load (optional equipment)</b> Indicates rated outrigger load.</p>	

## 8.12 Outrigger and generator control console (optional equipment)

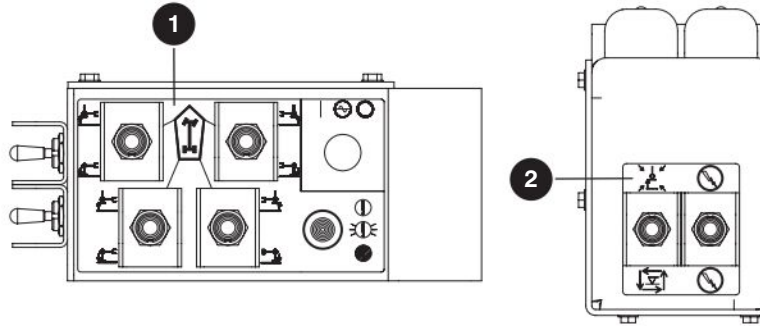

Description

Label Pictorial

### 1 Manual outrigger control console with generator

- Select retract or extend for each outrigger.
- Select to enable or to disable generator.
- **Indicates leveling system status:**
- **Off** : The outriggers are fully retracted.
- **Flashing Rapidly**: The outriggers are extending but the platform is not level.
- **Flashing**: The outriggers are extended but the platform is not yet level.
- **Solid**: The outriggers are extended and the platform is level.

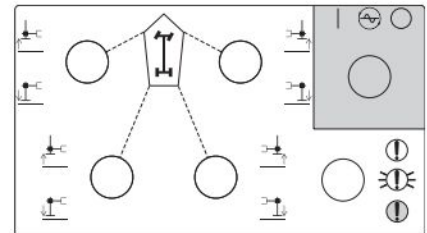

### 2 Automatic outrigger control console

- Select to retract all outriggers or to extend all outriggers with automatic leveling.
- Select to enable manual or automatic outrigger controls.

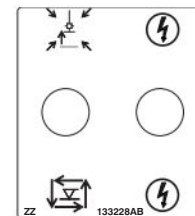

### 8.13 Air supply options (optional equipment)

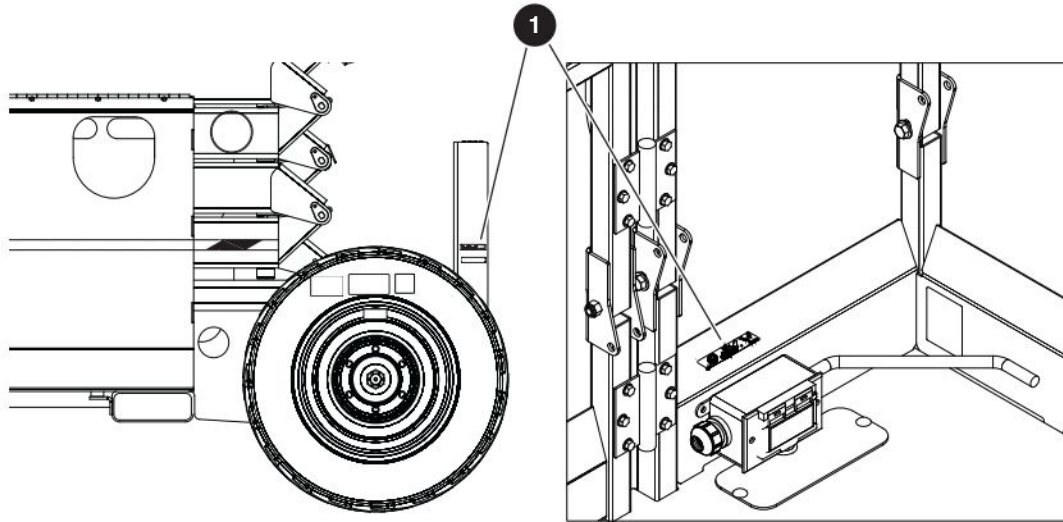

Description

Label Pictorial

- 1 Connect air supply**  
Connect platform air supply here.





---

## Section 9 – Unique Skyjack Features

Your Skyjack MEWP may be equipped with these unique features:

### **ACCESSORYZERS™**

Having equipment with features and functionality that allow you and your customers to do more is a vital part of the utilization equation. Skyjack offers a range of accessory products to expand a MEWP's functionality and your power to offer a truly flexible rental choice.

### **SKYCODED™**

A proven and reliable, relay-based control system, incorporating Skyjack's color coded and numbered wiring system, make our machines the easiest to trouble shoot and repair which means easier maintenance and lowered costs.



# WARNING

Cancer and Reproductive Harm-  
<https://www.p65warnings.ca.gov/>





**SKYJACK™**

[www.skyjack.com](http://www.skyjack.com)